



*smart*  
**Objectives**  
**UV, NUV, VISIBLE & NIR**

 **OptoSigma<sup>®</sup>**  
[www.global-optosigma.com](http://www.global-optosigma.com)

# INDEX

Classification of objective lenses	2
Part number description	2
Objectives List	3
Application SYSTEMS	5
Long Working Distance Objective Lenses (EPL / EPLE)	6
Long Work Distance Objective Lenses (PAL)	7
Long Work Distance Objective Lenses (PAL-L)	8
Ultra-violet Objective Lenses (PFL-UV-AG)	9
Ultra-violet Objective Lenses with Cover Glass thickness compensation (PFL-UV-AG-LC)	10
Near Ultra-violet Objective Lenses (PAL-NUV)	11
Near Ultra-violet Objective Lenses with Cover Glass thickness compensation (PAL-NUV-LC)	12-13
Near Infrared Objective Lenses (PAL-NIR)	14
Near Infrared Objective Lenses with Cover Glass thickness compensation (PAL-NIR-LC)	15
Ultra-violet Objective Lenses (PFL-UV / NUV-AG)	16
Near Infrared Objective Lenses with Cover Glass thickness compensation (PAL-NIR(780))	17
Tube Lenses (TL-Y3 / TL-Y4)	18
Custom-made (Water immersion objective lens (Purified water), X-ray Coaxial Zoom Observation System, Objective Lens for Vacuum with Transparent Hole)	19-21
Telecentric Zoom Microscope (SIZM)	22-23
Observation Unit with Coaxial Illumination (OUCI-2)	24
Observation Unit with Coaxial Illumination with 2 Camera Port (OUCI-M1M1)	25
Laser Processing Lens Barrel (OUCI-M1Y4)	27
Option	28-32
Technical Data	33-37

## Classification of objective lenses

An objective lens with tunable glass thickness compensation function is also available. Please contact our Sales Team.

Parfocal distance / Screw size	Corresponding wavelength	Glass thickness compensation	Product Name Part Number	Main purpose of use
45mm φ20.32×0.706	Visible	None	Bright field long working Objective Lenses <b>EPL / EPLE</b>	Visual observation
95mm φ26×0.706	Visible	None	Bright field long working Objective Lenses <b>PAL / PAL-L</b>	Visual observation
	Visible /Near ultra-violet	None/0.7mm/1.1mm	Bright field near ultra-violet Objective Lenses <b>PAL-NUV</b>	Visual /Near ultra violet observation Laser processing
	Visible /Near-infrared	None/0.7mm/1.1mm	Bright field near-infrared Objective Lenses <b>PAL-NIR</b>	Visual/ Near-infrared observation Laser processing
	Visible / Ultra-violet	None/0.7mm/1.1mm	Bright field ultra-violet Objective Lenses <b>PFL-UV-AG</b>	Visual/ultra-violet observation Laser processing

## Part number description

**PAL-50-NIR-□-□-LC00-A**

①                      ②                      ③                      ④                      ⑤⑥                      ⑦                      ⑧

① Lens type

**PAL** : Plan apochromat  
**PFL** : Plan semi-apochromat  
 (Plan Flour)

② Magnification

The magnification of objective lenses

③ Wavelength

None: Visible range  
**NIR**: Near-infrared  
**NUV**: Near ultra-violet  
**UV**: Ultra-violet

④ Resolution

None: Normal resolution  
**HR**: High resolution

⑤ Working distance L: Long working distance

⑥ AG Air gap type (Only to the UV type)

⑦ Glass thickness

**LC00**: Glass thickness is not corrected

**LC07**: Glass thickness is corrected to t=0.7mm

**LC11** : Glass thickness is corrected to t=1.1mm

⑧ Ver information A ~ Last updated ver.

\*Blank are omitted left-justified

Exp.)PAL-50-NUV-HR-L-LC11-A

# [Reference] Objectives List



Type	Magnification	Part Number	Description	NA	W.D.	Page
Visible Normal type	2x	<b>PAL-2-B</b>	MPlanApo 2x	0.055	34	P7
	5x	<b>PAL-5</b>	MPlanApo 5x	0.14	41	
	10x	<b>PAL-10-A</b>	MPlanApo 10x	0.3	34	
	20x	<b>PAL-20</b>	MPlanApo 20x	0.42	20	
	50x	<b>PAL-50</b>	MPlanApo 50x	0.55	13	
Visible Super long type	20x	<b>PAL-20-L-A</b>	MPlanApo SL 20x	0.3	31.1	P8
	100x	<b>PAL-100-L</b>	MPlanApo SL 100x	0.53	12.1	
UV(266 532) Normal type Air gap	10x	<b>PFL-10-UV-AG</b>	MPlan UV 10x	0.2	13.5	P9
	20x	<b>PFL-20-UV-AG-A</b>	MPlan UV 20x	0.36	15.07	
	50x	<b>PFL-50-UV-AG-A</b>	MPlan UV 50x	0.42	12	
	80x	<b>PFL-80-UV-AG-LC00</b>	MPlan UV 80x	0.55	10	
UV(266 532) Glass Thickness Compensation (t0.7)Type Air gap	20x	<b>PFL-20-UV-AG-LC07-A</b>	LCD MPlan UV 20x (t0.7)	0.36	15.15(Air)	P10
	50x	<b>PFL-50-UV-AG-LC07-A</b>	LCD MPlan UV 50x (t0.7)	0.42	11.99(Air)	
	80x	<b>PFL-80-UV-AG-LC07</b>	LCD MPlan UV 80x (t0.7)	0.55	9.78(Air)	
UV(266 532) Glass Thickness Compensation (t1.1)Type Air gap	20x	<b>PFL-20-UV-AG-LC11-A</b>	LCD MPlan UV 20x (t1.1)	0.36	15.2(Air)	P10
	50x	<b>PFL-50-UV-AG-LC11-A</b>	LCD MPlan UV 50x (t1.1)	0.42	12.02(Air)	
	80x	<b>PFL-80-UV-AG-LC11</b>	LCD MPlan UV 80x (t1.1)	0.55	9.65(Air)	
NUV(355 532) Normal type	20x	<b>PAL-20-NUV-A</b>	MPlan NUV 20x	0.4	17.25	P11
	50x	<b>PAL-50-NUV-A</b>	MPlan NUV 50x	0.45	15.1	
	100x	<b>PAL-100-NUV-A</b>	MPlan NUV 100x	0.57	11.23	
NUV(355 532) HR type	50x	<b>PAL-50-NUV-HR-L</b>	MPlan NUV HR 50x	0.65	10	P11
	100x	<b>PAL-100-NUV-HR</b>	MPlan NUV HR 100x	0.7	10	
NUV(355 532) Glass Thickness Compensation (t0.7)Type	20x	<b>PAL-20-NUV-LC07-A</b>	LCD MPlan NUV 20x (t0.7)	0.4	17.35(Air)	P12
	50x	<b>PAL-50-NUV-LC07-A</b>	LCD MPlan NUV 50x (t0.7)	0.45	15.05(Air)	
	100x	<b>PAL-100-NUV-LC07-A</b>	LCD MPlan NUV 100x (t0.7)	0.57	11.17(Air)	
NUV(355 532) Glass Thickness Compensation (t1.1)Type	20x	<b>PAL-20-NUV-LC11-A</b>	LCD MPlan NUV 20x (t1.1)	0.4	17.4(Air)	P12
	50x	<b>PAL-50-NUV-LC11-A</b>	LCD MPlan NUV 50x (t1.1)	0.45	15.01(Air)	
	100x	<b>PAL-100-NUV-LC11-A</b>	LCD MPlan NUV 100x (t1.1)	0.57	11.13(Air)	
NUV(355 532) HR Glass Thickness Compensation (t0.7)Type	50x	<b>PAL-50-NUV-HR-L-LC07-A</b>	LCD MPlan NUV HR 50x (t0.7)	0.65	9.91(Air)	P12
NUV(355 532) HR Glass Thickness Compensation (t1.1)Type	50x	<b>PAL-50-NUV-HR-L-LC11-A</b>	LCD MPlan NUV HR 50x (t1.1)	0.65	9.89(Air)	P12
NIR(1064 532) Normal type	10x	<b>PAL-10-NIR</b>	MPlan NIR 10x	0.3	31	P14
	20x	<b>PAL-20-NIR-LC00</b>	MPlan NIR 20x	0.4	20.2	
	50x	<b>PAL-50-NIR-L</b>	MPlan NIR 50x	0.45	15.1	
	100x	<b>PAL-100-NIR</b>	MPlan NIR 100x	0.53	12.14	
NIR(1064 532) HR type	20x	<b>PAL-20-NIR-HR-LC00</b>	MPlan NIR HR 20x	0.45	20	P14
	50x	<b>PAL-50-NIR-HR-LC00</b>	MPlan NIR HR 50x	0.67	10	
NIR(1064 532) Glass Thickness Compensation (t0.7)Type	20x	<b>PAL-20-NIR-LC07</b>	LCD MPlan NIR 20x (t0.7)	0.4	19.98(Air)	P15
	50x	<b>PAL-50-NIR-L-LC07</b>	LCD MPlan NIR 50x (t0.7)	0.45	15.01(Air)	
	100x	<b>PAL-100-NIR-L-LC07</b>	LCD MPlan NIR 100x (t0.7)	0.53	12.18(Air)	
NIR(1064 532) Glass Thickness Compensation (t0.7)Type	20x	<b>PAL-20-NIR-LC11</b>	LCD MPlan NIR 20x (t1.1)	0.4	19.85(Air)	P15
	50x	<b>PAL-50-NIR-L-LC11</b>	LCD MPlan NIR 50x (t1.1)	0.45	14.97(Air)	
	100x	<b>PAL-100-NIR-LC11</b>	LCD MPlan NIR 100x (t1.1)	0.53	12.16(Air)	
NIR(1064 532) HR Glass Thickness Compensation (t0.7)Type	50x	<b>PAL-50-NIR-HR-LC07</b>	LCD MPlan NIR HR 50x (t0.7)	0.67	10.48(Air)	P15
UV/NUV(266 355 532) Normal type Air gap	10x	<b>PFL-10-UV/NUV-AG</b>	MPlan UV/NUV 10	0.2	13.5	P16
	20x	<b>PFL-20-UV/NUV-AG-A</b>	MPlan UV/NUV 20	0.36	15.07	
	50x	<b>PFL-50-UV/NUV-AG-A</b>	MPlan UV/NUV 50	0.42	12	
Femtosecond NIR (780) Glass Thickness Compensation (t0.7)Type	20x	<b>PAL-20-NIR(780)-LC07</b>	LCD MPlanApo NIR(780) 20x(780)	0.45	17.2(Air)	P17
	50x	<b>PAL-50-NIR(780)-LC07</b>	LCD MPlanApo NIR(780) 50x(780)	0.8	3.8(Air)	

## Reliable integrated in-house production systems

We are operating an integrated in-house production system from planning, designing, manufacturing and to assembly. This one-stop production system contributes a lot about higher quality and shorter production time of our products as well as quality assurance and capability to deal with any technical issues.

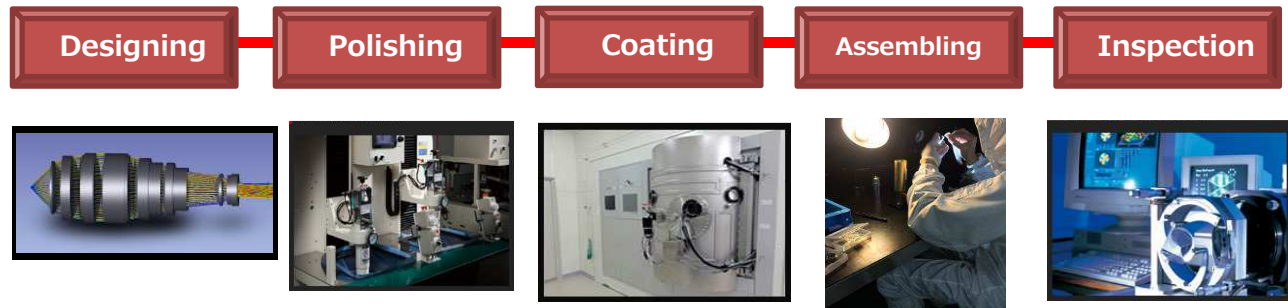

We are doing transmitted wave front inspection for all of the objectives when assembling. Totally eliminating the production error of each part and assembly errors, we are maintaining continual high quality of our products.

## Applications

### Laser processing System

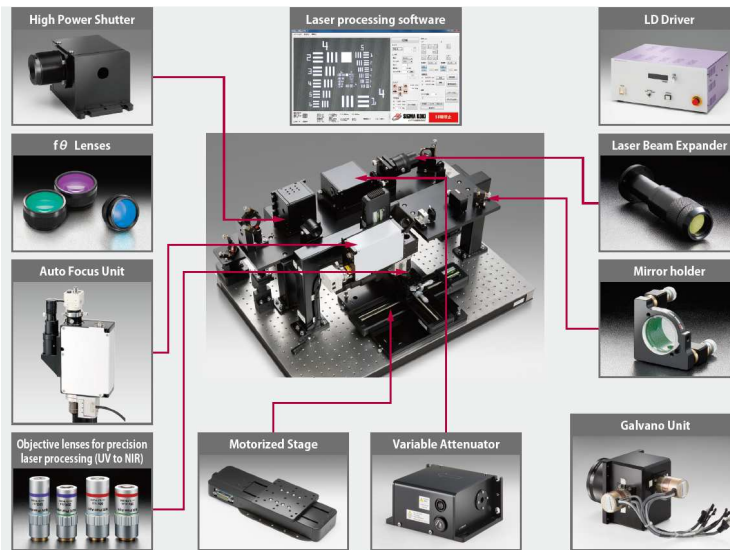

### Applications (Process example, Sample image)

- Cutting
- Drilling
- Scribing
- Trimming
- Marking
- Welding
- Hardening
- Annealing
- Laser deposition
- Glazing

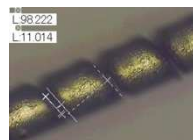

Spiral processing to steel wire

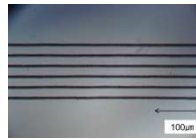

Direct etching to photomask blanks  
100mm/s

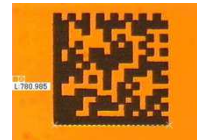

Pattern placement to Au thin film.

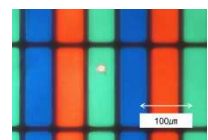

LCD color filter repair

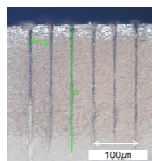

Scribing to Silicon wafer

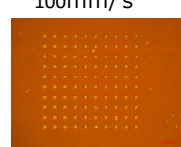

Through hole (dia. 50μm)  
on a polyimide film

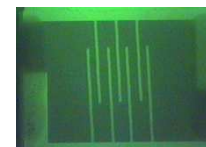

Trimming to resistor chip



Pattering to ITO thin film  
100mm/s

# Application SYSTEMS

## Laser Processing system



The laser oscillator part in the photo is "Callisto" from V-technology co., ltd..

### UV laser processing system with OUCI-M1Y4

High precision and high quality laser processing available with combination of UV/NUV/NIR objective lens.

Application

- FPD detect correction
- Cut and remove metal wiring
- Remove protective film, organic film, etc.
- Photomask correction
- Trimming, scribing, etc.

\*Please refer application example on page 4.

We also offer customization service. Please contact our sales for customization request.



Overview of laser processing system

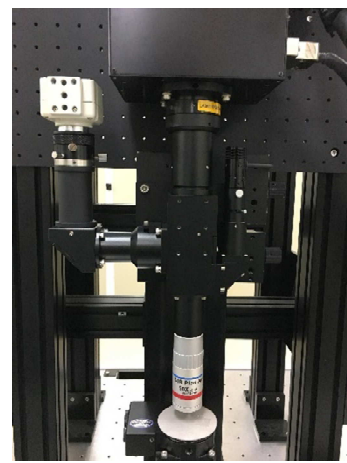

Enlarged image of OUCI-M1Y4 system

## Inverted OUCI unit (Phase-contrast)

The phase contrast inverted OUCI unit can observe the colorless and transparent sample by increasing the contrast using the refractive index difference between the sample and background light (diffraction and interference). Inverted OUCI unit is highly versatile to observe small samples (cells, microorganisms etc.).

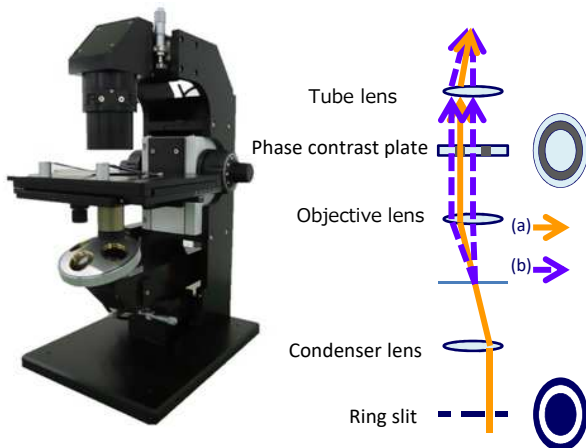

▶ Sample image (Cellulose) (Bacillariophyceae)  
(Color Camera 2/3inch 2-Mega pixel CMOS Camera)



Phase-contrast observation

Bright field observation

# Long Working Distance Objective Lenses **EPL/EPL** W3086

- Bright Field Inspection
- Infinity Corrected
- Plan Apochromat
- Well work with an Auto-Focusing system due to compact and lightweight design.



### Typical Transmittance Data

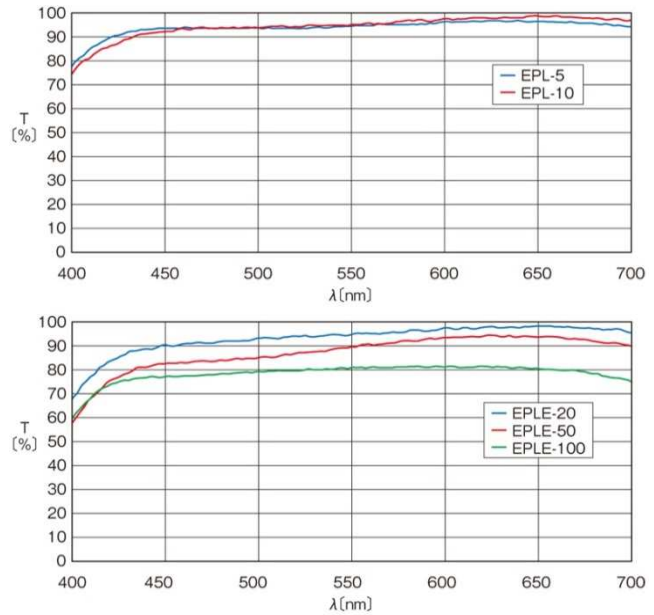

### Outline Drawing

**EPL-5**

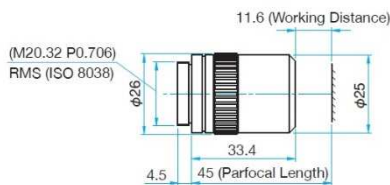

**EPL-10**

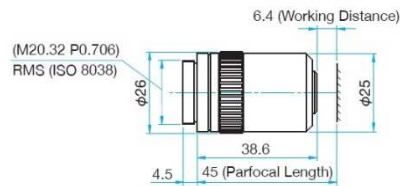

**EPL-20**

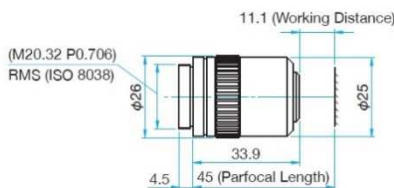

**EPL-50**

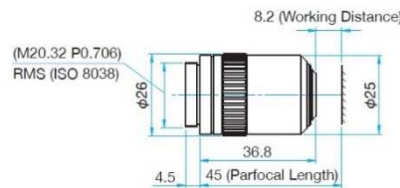

**EPL-100**

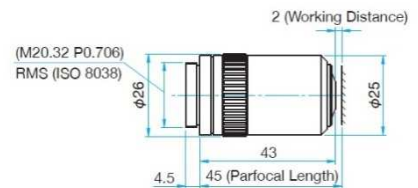

Part Number	Magnification	Focal length [mm]	N.A.	Working distance (W.D.) [mm]	Resolution [μm]	Focal depth ± D.F. [μm]	Real field of View [mm]		Weight [kg]
							(Eyepiece φ24mm) [mm]	(1/2" CCD)	
EPL-5	5x	40	0.13	11.6	2.1	16.3	φ 4.8	0.96 x 1.28	0.085
EPL-10	10x	20	0.3	6.4	0.9	3.1	φ 2.4	0.48 x 0.64	0.085
EPL-20	20x	10	0.4	11.1	0.7	1.7	φ 1.2	0.24 x 0.32	0.085
EPL-50	50x	4	0.55	8.2	0.5	0.9	φ 0.48	0.10 x 0.13	0.095
EPL-100	100x	2	0.8	2	0.3	0.4	φ 0.24	0.05 x 0.06	0.105

\*Resolution and focal depth are calculated value at wavelength of 0.55μm.

# Long Work Distance Objective Lenses

**PAL**

**RoHS**

**Catalog Code W3456**

- Bright Field Inspection
- Infinity Corrected
- Plan Apochromat



Typical Transmittance Data

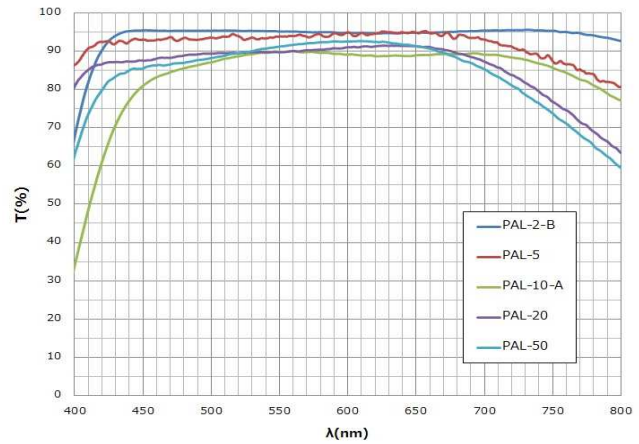

## Outline Drawing

**PAL-2-B**

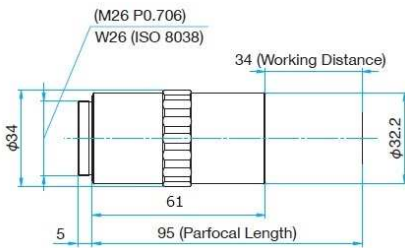

**PAL-5**

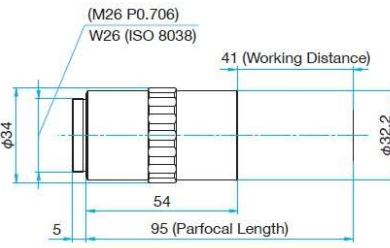

**PAL-10-A**

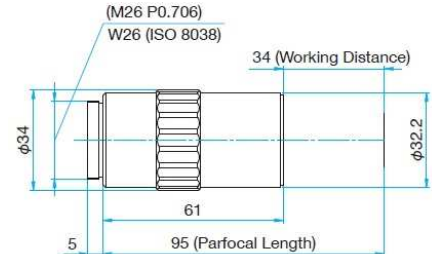

**PAL-20**

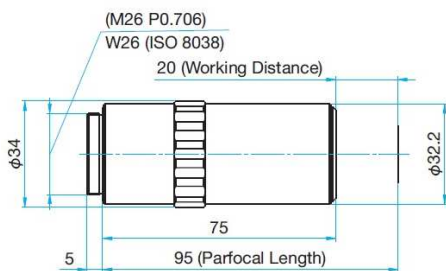

**PAL-50**

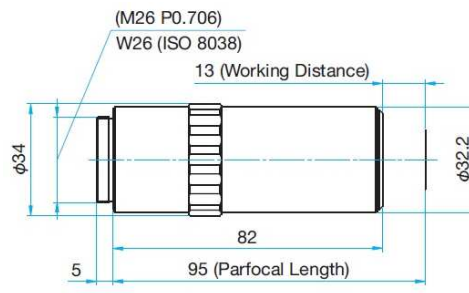

Part Number	Item name	Magnification	Focal length [mm]	N.A.	Working distance (W.D.) [mm]	Resolution [μm]	Focal depth ±D.F.[μm]	Real field of View [mm]		Weight [kg]
								(Eyepiece φ24mm) [mm]	(1/2" CCD)	
PAL-2-B	MPlanApo 2x	2x	100	0.055	34	5	91	φ 12	2.4 x 3.2	0.25
PAL-5	MPlanApo 5x	5x	40	0.14	41	2	14	φ 4.8	0.96 x 1.28	0.24
PAL-10-A	MPlanApo 10x	10x	20	0.3	34	0.92	3.1	φ 2.4	0.48 x 0.64	0.24
PAL-20	MPlanApo 20x	20x	10	0.42	20	0.65	1.6	φ 1.2	0.24 x 0.32	0.29
PAL-50	MPlanApo 50x	50x	4	0.55	13	0.5	0.9	φ 0.48	0.10 x 0.13	0.31

\* Resolution and focal depth are calculated value at wavelength of 0.55μm.

# Long Work Distance Objective Lenses

**PAL-L**

**RoHS**

**Catalog Code W3456**

- Bright Field Inspection
- Infinity Corrected
- Plan Apochromat



## Typical Transmittance Data

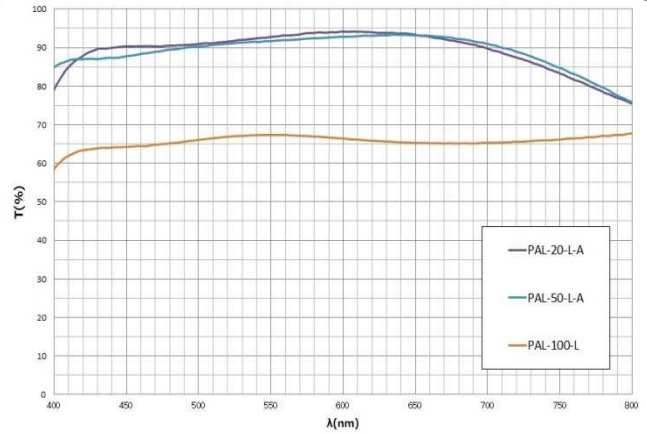

## Outline Drawing

### PAL-20-L-A

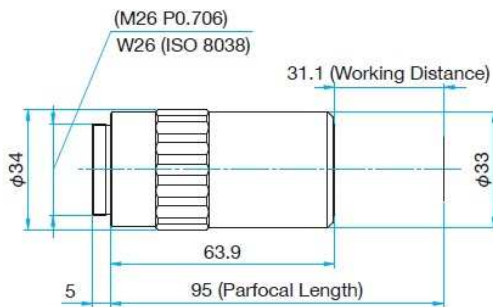

### PAL-100-L

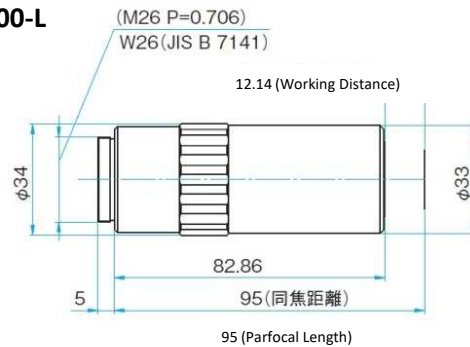

## Sample Image

(Observation unit with coaxial illumination OUCI-2, Objective Lens PAL-20-L-A, Color Camera 2/3inch 2-Mega pixel CMOS Camera)

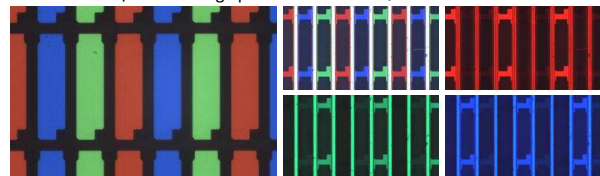

Color Filter (Transmitted lighting)

Color Filter (Epi illumination)

NA 0.3 (Resolution 0.9 $\mu$ m\*)  
 \*Calculated value: Reference Wavelength  
 Field of vision 0.55mm x 0.3mm  
 (Observation magnification 20x)

Part Number	Item name	Magnification	Focal length [mm]	N.A.	Working distance (W.D.) [mm]	Resolution [ $\mu$ m]	Focal depth $\pm$ D.F [ $\mu$ m]	Real field of View [mm]		Weight [kg]
								(Eyepiece $\phi$ 24mm)	(1/2" CCD)	
PAL-20-L-A	MPlanApo SL20x	20x	10	0.3	31.1	0.92	3.1	$\phi$ 1.2	0.24 x 0.32	0.28
PAL-100-L	MPlanApo SL 100x	100x	2	0.53	12.14	0.52	0.98	$\phi$ 0.24	0.05 x 0.06	0.34

\*Resolution and focal depth are calculated value at wavelength of 0.55 $\mu$ m.

# Ultra-violet Objective Lenses

## PFL-UV-AG

RoHS

Catalog Code W3459

- Bright Field Inspection and Laser processing
- Infinity Corrected
- 266nm and 532nm
- Higher Laser damage threshold with Air-gap design.

Laser damage threshold

※Pulse width:10ns, Frequency:20Hz,reference value

0.09 J/cm<sup>2</sup> (266nm) , 0.2 J/cm<sup>2</sup> (532nm)



### Typical Transmittance Data

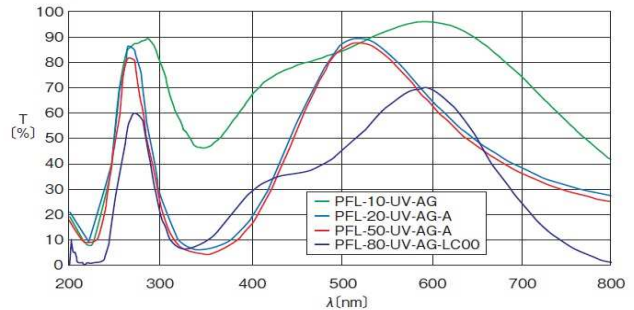

### Outline Drawing

#### PFL-10-UV-AG

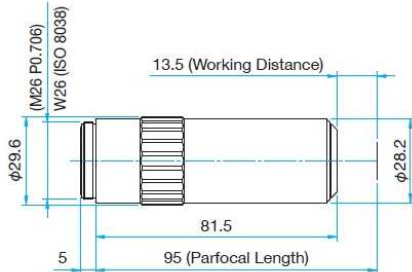

#### PFL-20-UV-AG-A

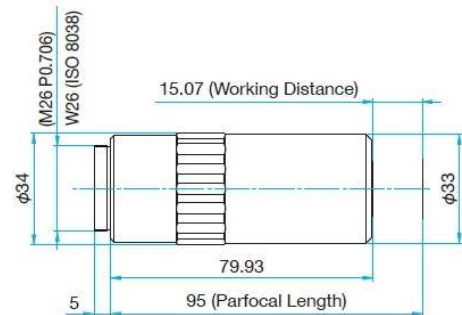

#### PFL-50-UV-AG-A

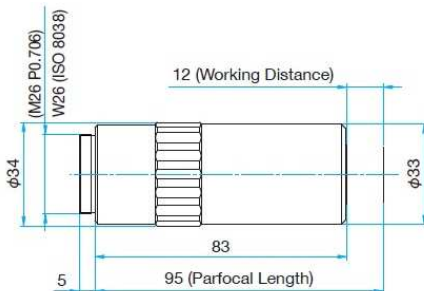

#### PFL-80-UV-AG-LC00

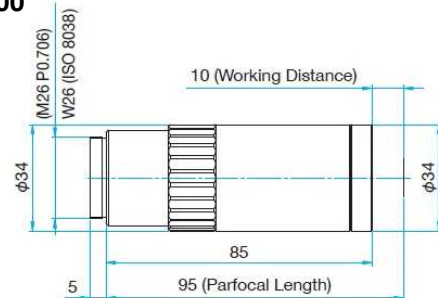

Part Number	Item name	Magnification	Focal length [mm]	N.A.	Working distance (W.D.) [mm]	Resolution [μm]	Focal depth ±D.F.[μm]	Real field of View [mm]		Weight [kg]
								(Eyepiece φ24mm) [mm]	(1/2" CCD)	
PFL-10-UV-AG	MPlan UV 10x	10x	20	0.2	13.5	1.4	6.9	φ2.4	0.48 x 0.64	0.3
PFL-20-UV-AG-A	MPlan UV 20x	20x	10	0.36	15.07	0.76	2.1	φ1.2	0.24 x 0.32	0.35
PFL-50-UV-AG-A	MPlan UV 50x	50x	4	0.42	12	0.65	1.6	φ0.48	0.10 x 0.13	0.41
PFL-80-UV-AG-LC00	MPlan UV 80x	80x	2.5	0.55	10	0.5	0.9	φ0.3	0.06 x 0.08	0.35

\*Resolution and focal depth are calculated value at wavelength of 0.55μm.

# Ultra-violet Objective Lenses with Cover Glass thickness compensation PFL-UV-AG-LC

RoHS

Catalog Code W3463

- Bright Field Inspection and Laser processing
- Infinity Corrected
- 266nm and 532nm
- Cover glass thickness compensation (t=0.7mm and 1.1mm)
- Higher Laser damage threshold with Air-gap design

Laser damage threshold

※Pulse width:10ns, Frequency:20Hz, reference value

0.09 J/cm<sup>2</sup> (266nm), 0.2 J/cm<sup>2</sup> (532nm)



Typical Transmittance Data

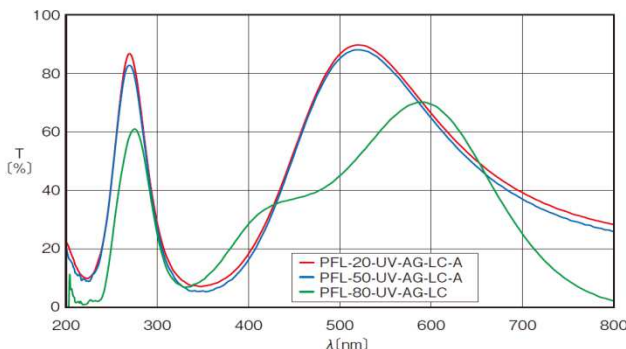

## Outline Drawing

PFL-20-UV-AG-LC07-A

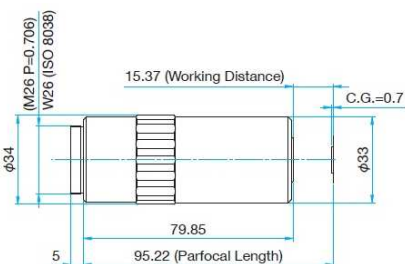

PFL-20-UV-AG-LC11-A

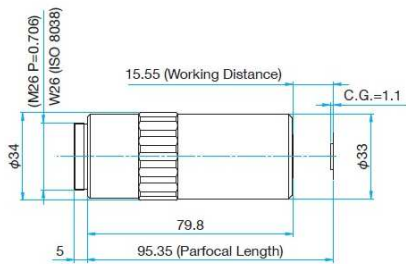

PFL-50-UV-AG-LC07-A

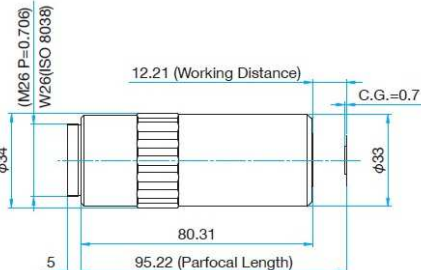

PFL-50-UV-AG-LC11-A

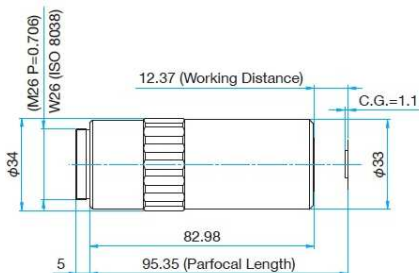

PFL-80-UV-AG-LC07

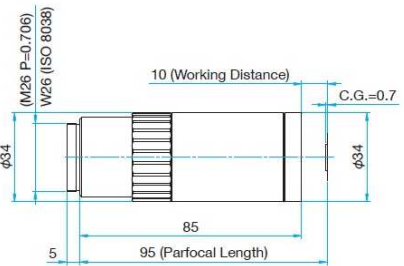

PFL-80-UV-AG-LC11

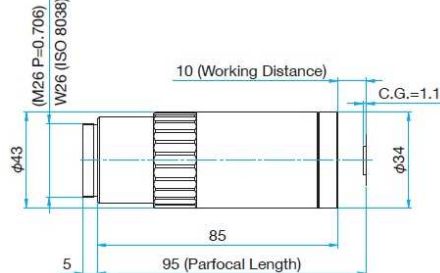

Part Number	Item name	Magnification	Focal length [mm]	N.A.	Working distance (W.D.) [mm]	Resolution [μm]	Focal depth ±D.F[μm]	Real field of View [mm]		Weight [kg]
								(Eyepiece φ24mm) [mm]	(1/2" CCD)	
PFL-20-UV-AG-LC07-A	LCD MPlan UV 20x(t0.7)	20x	10	0.36	15.15	0.76	2.1	φ1.2	0.24 x 0.32	0.35
PFL-20-UV-AG-LC11-A	LCD MPlan UV 20x(t1.1)	20x	10	0.36	15.2	0.76	2.1	φ1.2	0.24 x 0.32	0.35
PFL-50-UV-AG-LC07-A	LCD MPlan UV 50x(t0.7)	50x	4	0.42	11.99	0.65	1.6	φ0.48	0.10 x 0.13	0.4
PFL-50-UV-AG-LC11-A	LCD MPlan UV 50x(t1.1)	50x	4	0.42	12.02	0.65	1.6	φ0.48	0.10 x 0.13	0.4
PFL-80-UV-AG-LC07	LCD MPlan UV 80x(t0.7)	80x	2.5	0.55	9.78	0.5	0.9	φ0.3	0.06 x 0.08	0.35
PFL-80-UV-AG-LC11	LCD MPlan UV 80x(t1.1)	80x	2.5	0.55	9.65	0.5	0.9	φ0.3	0.06 x 0.08	0.35

\*Resolution and focal depth are calculated value at wavelength of 0.55μm. \*Working distance: value at air

# Near Ultra-violet Objective Lenses **PAL-NUV**

**RoHS**

**Catalog Code** W3458

- Bright Field Inspection and Laser processing
- Infinity Corrected
- Plan Apochromat
- Near-UV 355nm and 532nm
- Laser damage threshold

※Pulse width:10ns, Frequency:20Hz, reference value  
**0.05 J/cm<sup>2</sup> (355nm), 0.1 J/cm<sup>2</sup> (532nm)**



Typical Transmittance Data

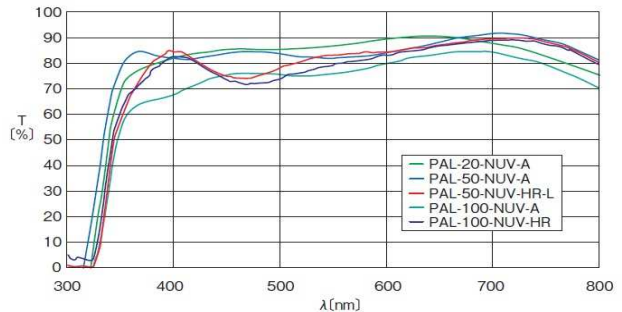

## Outline Drawing

**PAL-20-NUV-A**

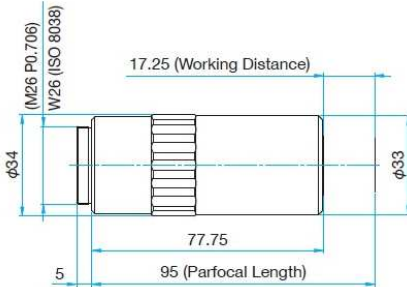

**PAL-50-NUV-A**

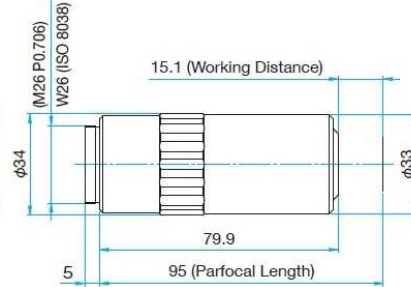

**PAL-50-NUV-HR-L**

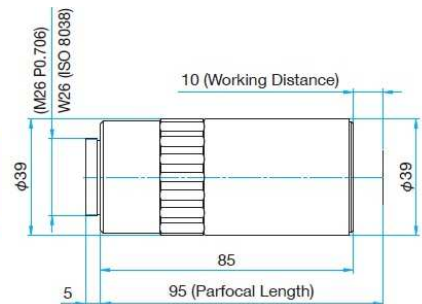

**PAL-100-NUV-A**

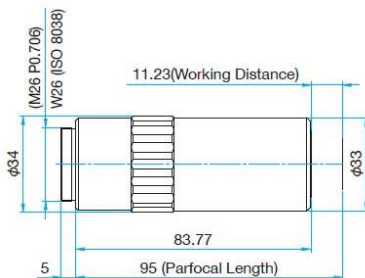

**PAL-100-NUV-HR**

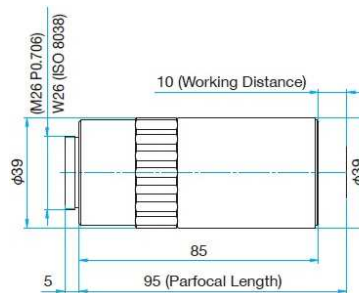

Part Number	Item name	Magnification	Focal length [mm]	N.A.	Working distance (W.D.) [mm]	Resolution [μm]	Focal depth ±D.F[μm]	Real field of View [mm]		Weight [kg]
								(Eyepiece φ24mm) [mm]	(1/2" CCD)	
PAL-20-NUV-A	MPlanApo NUV 20x	20x	10	0.4	17.25	0.69	1.7	φ1.2	0.24 x 0.32	0.35
PAL-50-NUV-A	MPlanApo NUV 50x	50x	4	0.45	15.1	0.61	1.4	φ0.48	0.10 x 0.13	0.36
PAL-50-NUV-HR-L	MPlanApo NUV HR 50x	50x	4	0.65	10	0.42	0.65	φ0.48	0.10 x 0.13	0.51
PAL-100-NUV-A	MPlanApo NUV 100x	100x	2	0.57	11.23	0.48	0.8	φ0.24	0.05 x 0.06	0.38
PAL-100-NUV-HR	MPlanApo NUV HR 100x	100x	2	0.7	10	0.39	0.6	φ0.24	0.05 x 0.06	0.53

\*Resolution and focal depth are calculated value at wavelength of 0.55μm.

# Near Ultra-violet Objective Lenses with Cover Glass thickness compensation

## PAL-NUV-LC

RoHS

Catalog Code W3464

- Bright Field Inspection and Laser processing
- Infinity Corrected
- Near UV (355nm)
- Cover glass thickness compensation (t=0.7mm and 1.1mm)
- Plan Apochromat
- Laser damage threshold

※Pulse width:10ns, Frequency:20Hz ,reference value  
**0.05 J/cm<sup>2</sup> (355nm), 0.1 J/cm<sup>2</sup> (532nm)**



Typical Transmittance Data

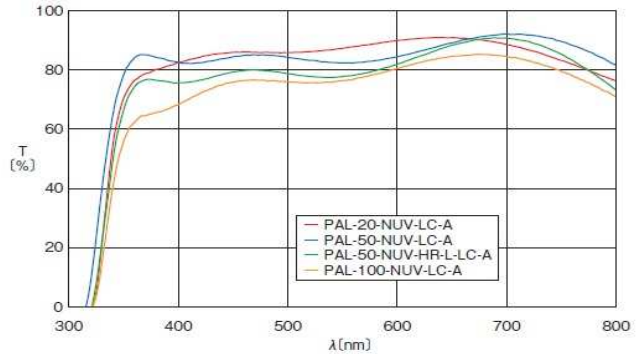

### Outline Drawing

PAL-20-NUV-LC07-A

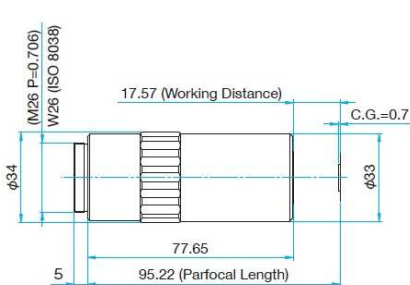

PAL-20-NUV-LC11-A

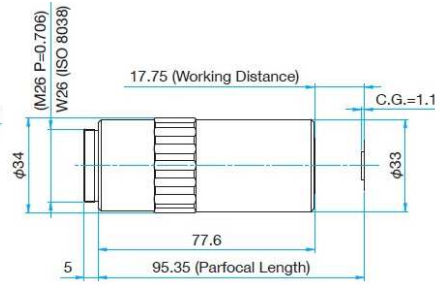

PAL-50-NUV-LC07-A

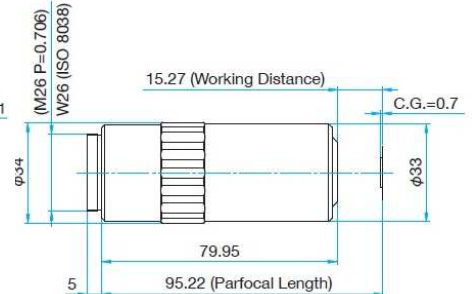

PAL-50-NUV-LC11-A

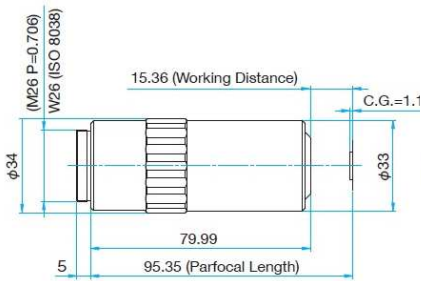

PAL-50-NUV-HR-L-LC07-A

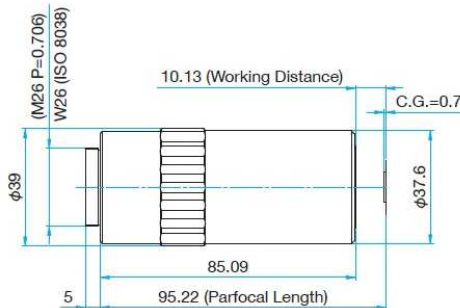

PAL-50-NUV-HR-L-LC11-A

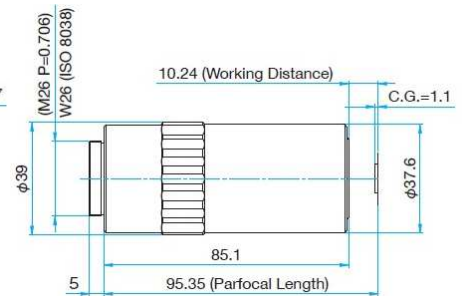

### PAL-100-NUV-LC07-A

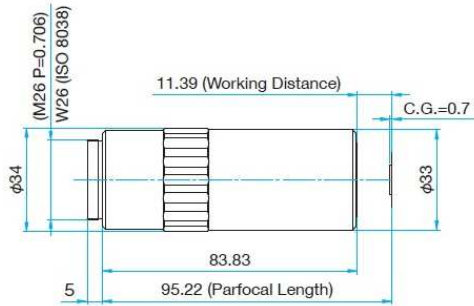

### PAL-100-NUV-LC11-A

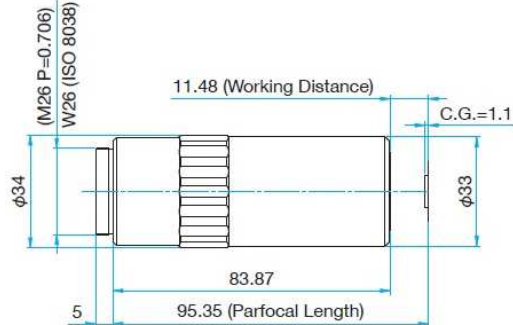

Part Number	Item name	Magnification	Focal length [mm]	N.A.	Working distance (W.D.) [mm]	Resolution [μm]	Focal depth ±D.F[μm]	Real field of View [mm]		Weight [kg]
								(Eyepiece φ24mm) [mm]	(1/2" CCD)	
PAL-20-NUV-LC07-A	LCD MPlanApo NUV 20x (t0.7)	20x	10	0.4	17.35	0.69	1.7	φ1.2	0.24 x 0.32	0.35
PAL-20-NUV-LC11-A	LCD MPlanApo NUV 20x(t1.1)	20x	10	0.4	17.4	0.69	1.7	φ1.2	0.24 x 0.32	0.35
PAL-50-NUV-LC07-A	LCD MPlanApo NUV 50x (t0.7)	50x	4	0.45	15.05	0.61	1.4	φ0.48	0.10 x 0.13	0.36
PAL-50-NUV-LC11-A	LCD MPlanApo NUV 50x(t1.1)	50x	4	0.45	15.01	0.61	1.4	φ0.48	0.10 x 0.13	0.36
PAL-50-NUV-HR-L-LC07-A	LCD MPlanApo NUV HR 50x(t0.7)	50x	4	0.65	9.91	0.42	0.7	φ0.48	0.10 x 0.13	0.51
PAL-50-NUV-HR-L-LC11-A	LCD MPlanApo NUV HR 50x(t1.1)	50x	4	0.65	9.89	0.42	0.7	φ0.48	0.10 x 0.13	0.51
PAL-100-NUV-LC07-A	LCD MPlanApo NUV 100x (t0.7)	100x	2	0.57	11.17	0.48	0.8	φ0.24	0.05 x 0.06	0.39
PAL-100-NUV-LC11-A	LCD MPlanApo NUV 100x(t1.1)	100x	2	0.57	11.13	0.48	0.8	φ0.24	0.05 x 0.06	0.39

\*Resolution and focal depth are calculated value at wavelength of 0.55μm. \*Working distance: value at air.

#### Comparison of sample image of conventional objective lens and HR objective lens

(Observation unit with coaxial illumination OUCI-2, 2/3 inch 2 million pixels CMOS color camera, filed of vision 0.22mm×0.12mm[magnification 20x])

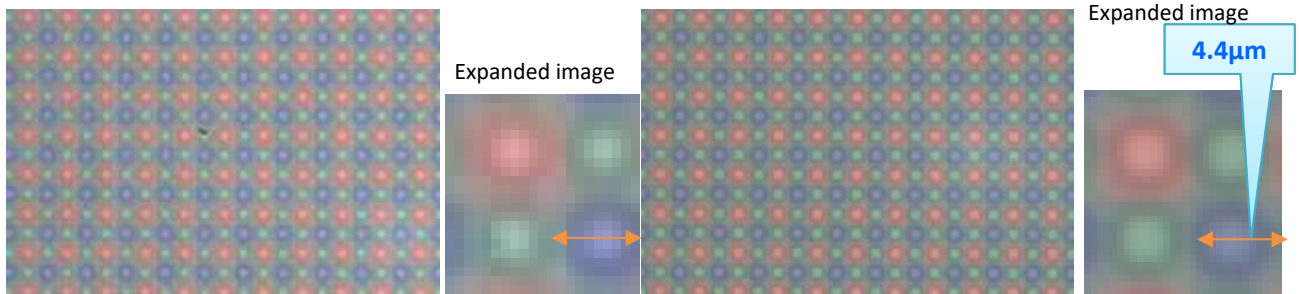

CCD [50x] : PAL-50 (Conventional model)

CCD [×50HR] : PAL-50-NIR-HR-LC00

Observation unit with coaxial illumination that can be customized is also available.

**Catalog Code** W2012



# Near Infrared Objective Lenses

## PAL-NIR



Catalog Code W3457

- Bright Field Inspection and Laser processing
- Infinity Corrected
- 1064nm
- Plan Apochromat
- Laser damage threshold

※Pulse width:10ns, Frequency:20Hz ,reference value  
**0.1 J/cm<sup>2</sup> (532nm), 0.2 J/cm<sup>2</sup> (1064nm)**



Typical Transmittance Data

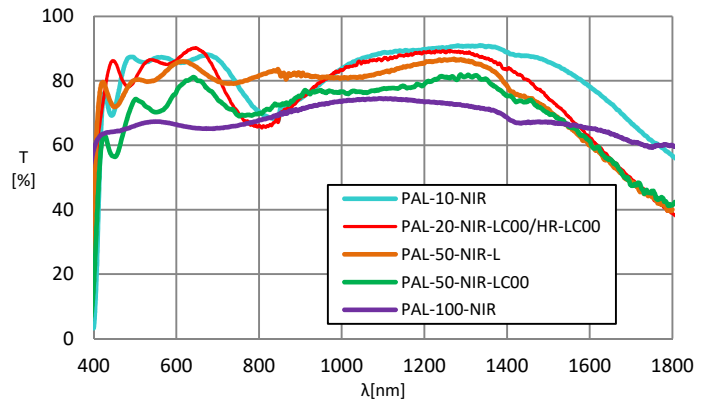

How to replace the protective glass unit of PAL-20-NIR-HR-LC00/PAL-50-NIR-HR-LC00

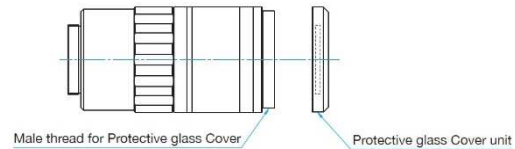

### Outline Drawing

#### PAL-10-NIR

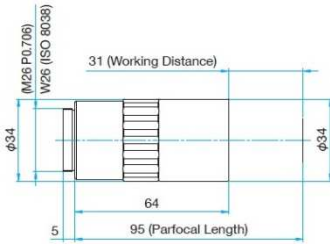

#### PAL-20-NIR-LC00

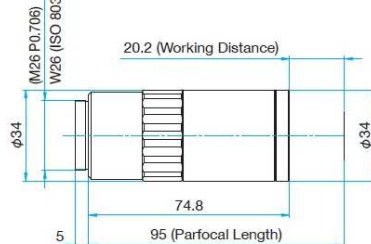

#### PAL-20-NIR-HR-LC00

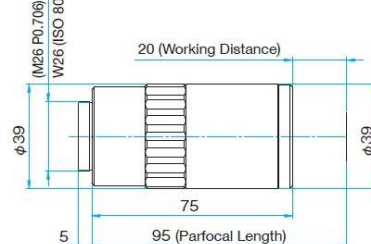

#### PAL-50-NIR-L

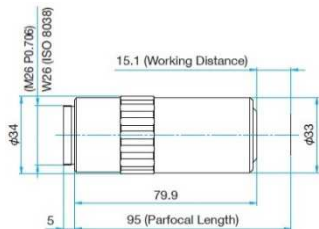

#### PAL-50-NIR-HR-LC00

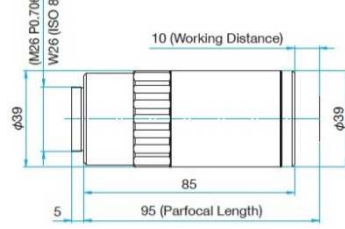

#### PAL-100-NIR

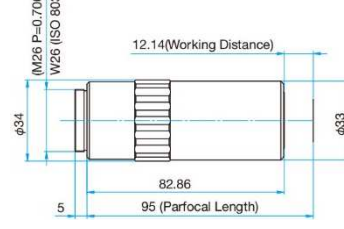

Part Number	Item name	Magnification	Focal length [mm]	N.A.	Working distance (W.D.) [mm]	Resolution [μm]	Focal depth ±D.F [μm]	Real field of View [mm]		Weight [kg]
								(Eyepiece φ24mm) [mm]	(1/2" CCD)	
PAL-10-NIR	MPlanApo NIR 10x	10x	20	0.3	31	0.92	3.1	φ2.4	0.48 x 0.64	0.3
PAL-20-NIR-LC00	MPlanApo NIR 20x	20x	10	0.4	20.2	0.69	1.7	φ1.2	0.24 x 0.32	0.36
PAL-20-NIR-HR-LC00	MPlanApo NIR HR 20x	20x	10	0.45	20	0.61	1.4	φ1.2	0.24 x 0.32	0.44
PAL-50-NIR-L	MPlanApo NIR 50x	50x	4	0.45	15.1	0.61	1.4	φ0.48	0.10 x 0.13	0.34
PAL-50-NIR-HR-LC00	MPlanApo NIR HR 50x	50x	4	0.67	10	0.41	0.61	φ0.48	0.10 x 0.13	0.48
PAL-100-NIR	MPlanApo NIR 100x	100x	2	0.53	12.14	0.52	0.98	φ0.24	0.05 x 0.06	0.34

\*Resolution and focal depth are calculated value at wavelength of 0.55μm.

# Near Infrared Objective Lenses with Cover Glass thickness compensation PAL-NIR-LC

- Bright Field Inspection and Laser processing
- Infinity Corrected
- Near UV (355nm)
- Cover glass thickness compensation (t=0.7mm and 1.1mm)
- Plan Apochromat
- Laser damage threshold

※Pulse width:10ns, Frequency:20Hz ,reference value  
0.05 J/cm<sup>2</sup> (355nm), 0.1 J/cm<sup>2</sup> (532nm)



Typical Transmittance Data

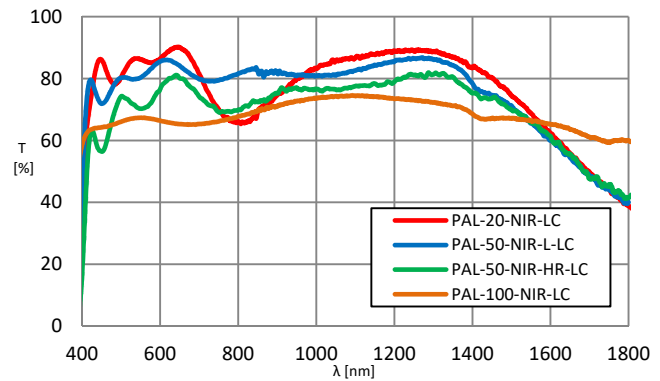

## Outline Drawing

PAL-20-NIR-LC07

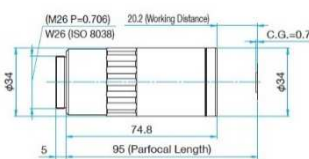

PAL-20-NIR-LC11

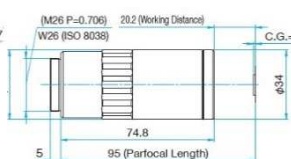

PAL-50-NIR-L-LC07

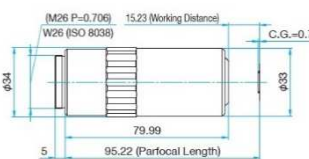

PAL-50-NIR-L-LC11

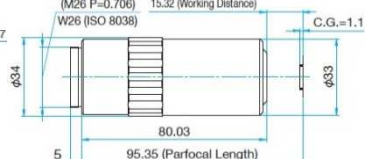

PAL-50-NIR-HR-LC07

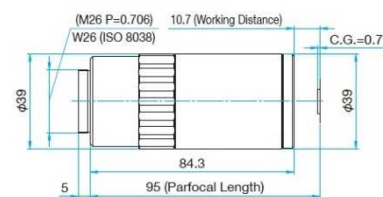

PAL-100-NIR-LC07

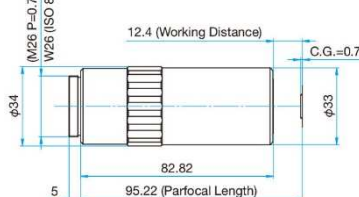

PAL-100-NIR-LC11

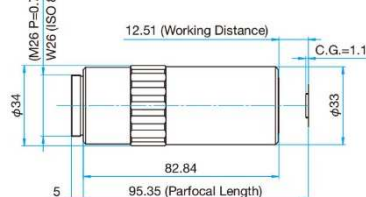

Part Number	Item name	Magnification	Focal length [mm]	N.A.	Working distance (W.D.) [mm]	Resolution [μm]	Focal depth ±D.F[μm]	Real field of View [mm]		Weight [kg]
								(Eyepiece φ24mm)	(1/2" CCD)	
PAL-20-NIR-LC07	LCD MPlanApo NIR 20x(t0.7)	20x	10	0.4	19.98	0.69	1.7	φ1.2	0.24 x 0.32	0.36
PAL-20-NIR-LC11	LCD MPlanApo NIR 20x(t1.1)	20x	10	0.4	19.85	0.69	1.7	φ1.2	0.24 x 0.32	0.36
PAL-50-NIR-L-LC07	LCD MPlanApo NIR 50x(t0.7)	50x	4	0.45	15.01	0.61	1.4	φ0.48	0.10 x 0.13	0.34
PAL-50-NIR-L-LC11	LCD MPlanApo NIR 50x(t1.1)	50x	4	0.45	14.97	0.61	1.4	φ0.48	0.10 x 0.13	0.34
PAL-50-NIR-HR-LC07	LCD MPlanApo NIR HR50x(t0.7)	50x	4	0.67	10.48	0.41	0.61	φ0.48	0.10 x 0.13	0.48
PAL-100-NIR-LC07	LCD MPlanApo NIR 100x(t0.7)	100x	2	0.53	12.18	0.52	1	φ0.24	0.05 x 0.06	0.33
PAL-100-NIR-LC11	LCD MPlanApo NIR 100x(t1.1)	100x	2	0.53	12.16	0.52	1	φ0.24	0.05 x 0.06	0.33

\*Resolution and focal depth are calculated value at wavelength of 0.55μm. \*Working distance: value at air

# Ultra-violet Objective Lenses **PFL-UV/NUV-AG** RoHS Catalog Code W3460

- Bright Field Inspection and Laser processing
- Infinity Corrected
- 266nm/355nm/532nm
- Higher Laser damage threshold with Air-gap design
- Laser damage threshold

※Pulse width:10ns, Frequency:20Hz ,reference value  
**0.09 J/cm<sup>2</sup> (266nm), 0.1 J/cm<sup>2</sup> (355nm)**  
**0.2 J/cm<sup>2</sup> (532nm)**



Typical Transmittance Data

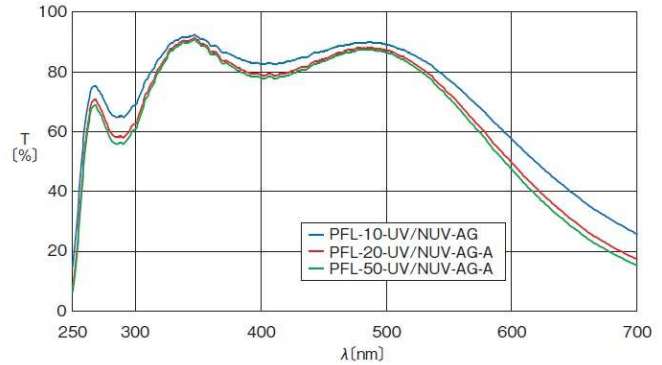

## Outline Drawing

**PFL-10-UV/NUV-AG**

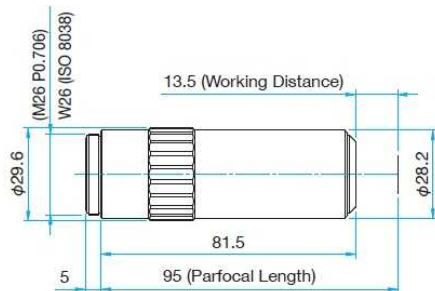

**PFL-20-UV/NUV-AG-A**

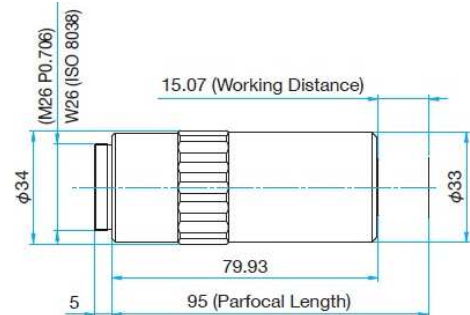

**PFL-50-UV/NUV-AG-A**

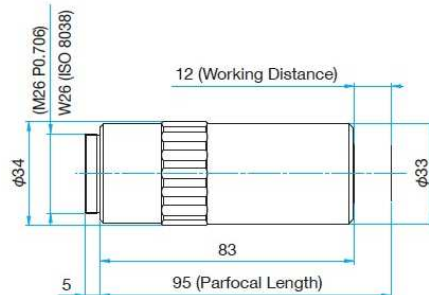

Part Number	Item name	Magnification	Focal length [mm]	N.A.	Working distance (W.D.) [mm]	Resolution [μm]	Focal depth ±D.F.[μm]	Real field of View [mm]		Weight [kg]
								(Eyepiece φ24mm) [mm]	(1/2" CCD)	
PFL-10-UV/NUV-AG	MPlan UV/NUV 10x	10x	20	0.2	13.5	1.4	6.9	φ2.4	0.48 x 0.64	0.3
PFL-20-UV/NUV-AG-A	MPlan UV/NUV 20x	20x	10	0.36	15.07	0.76	2.1	φ1.2	0.24 x 0.32	0.35
PFL-50-UV/NUV-AG-A	MPlan UV/NUV 50x	50x	4	0.42	12	0.65	1.6	φ0.48	0.10 x 0.13	0.41

\*Resolution and focal depth are calculated value at wavelength of 0.55μm.

# Near Infrared Objective Lenses with Cover Glass thickness compensation

## PAL-NIR(780)

- Bright Field Inspection and Laser processing
- Infinity Corrected
- Plan Apochromat
- 780nm
- Laser damage threshold

※Pulse width:10ns, Frequency:20Hz, reference value  
**0.1 J/cm<sup>2</sup> (532nm), 0.15 J/cm<sup>2</sup> (780nm)**



Typical Transmittance Data

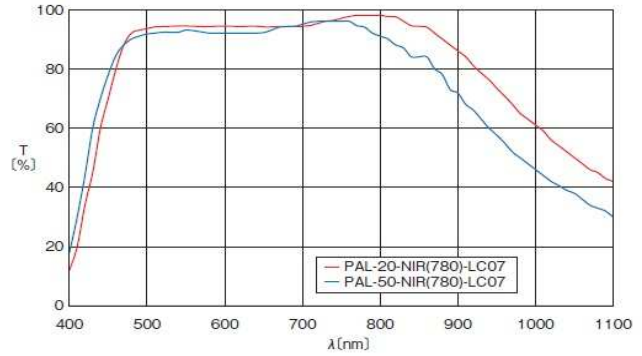

### Outline Drawing

PAL-20-NIR(780)-LC07

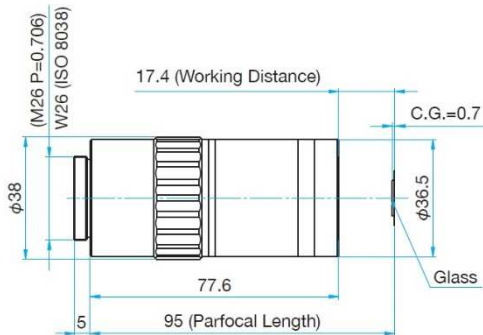

PAL-50-NIR(780)-LC07

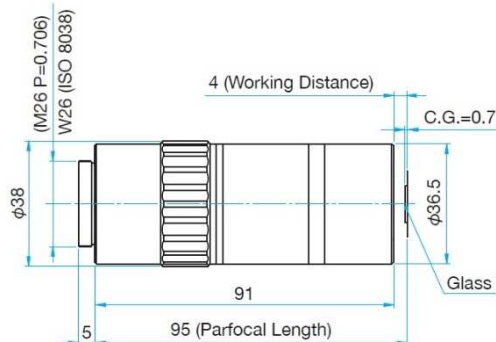

Part Number	Item name	Magnification	Focal length [mm]	N.A.	Working distance (W.D.) [mm]	Resolution [μm]	Focal depth ±D.F.[μm]	Real field of View [mm]		Weight [kg]
								(Eyepiece φ24mm)	(1/2" CCD)	
PAL-20-NIR(780)-LC07	LCD MPlanApo NIR(780) 20x(t0.7)	20x	10	0.45	17.2	0.6	1.4	φ1.2	0.24 x 0.32	0.34
PAL-50-NIR(780)-LC07	LCD MPlanApo NIR(780) 50x(t0.7)	50x	4	0.8	3.8	0.3	0.4	φ0.48	0.10 x 0.13	0.44

\*Resolution and focal depth are calculated value at wavelength of 0.55μm.

# Tube Lenses

**TL-Y**

**RoHS**

**Catalog Code**

**W3462**



- Designed specifically for fundamental and harmonic wavelengths of YAG and Fiber lasers.
- Two types are available.
- TL-Y3 : Compatible with wavelengths from fundamental to 3rd harmonic.
- TL-Y4 : Compatible with wavelengths from fundamental to 4th harmonic.

## Outline Drawing

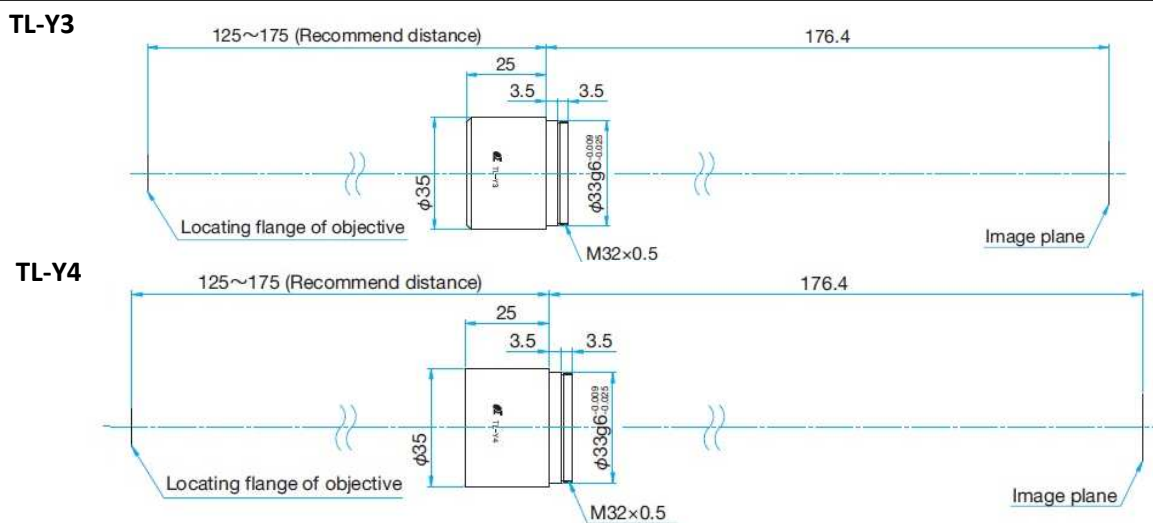

## Typical Transmittance Data

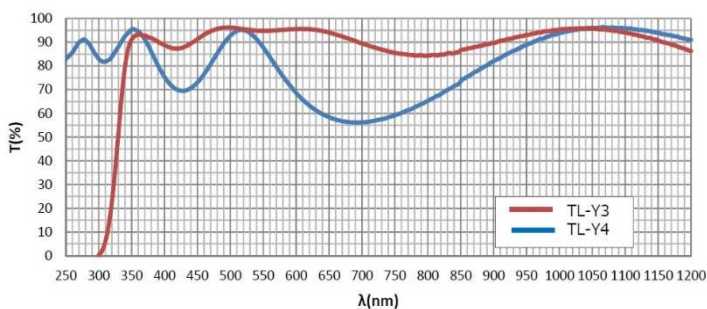

\*These tube lenses must be used by inputting collimated light from the end without threading. Inputting collimated beam from the threaded end results in large focusing spot size and blurred image due to large chromatic and spherical aberration.

\*Operating at unspecified wavelengths might result in large aberration and low transmittance.

Part Number	Wavelengths	Focal length [mm]	Imaging magnification	Entrance pupil [mm]	Image field size [mm]	Weight [kg]
TL-Y3	343nm, 355nm, 515nm, 532nm, 1030nm, 1064nm	200	1x	φ11.0	φ24	0.055
TL-Y4	257nm, 266nm, 343nm, 355nm, 515nm, 532nm, 1030nm, 1064nm	200	1x	φ11.0	φ24	0.055

# Custom-made

## Water immersion objective lens (Purified water)

Water immersion objective lens is filled with water between the objective lens and sample. No spherical aberration is caused when there are water between the sample and cover glass. It is susceptible to the thickness error because of the increased refractive index difference between the cover glass and water



- High NA, water immersion objective lens
- Low aberration (Field curvature image height : <math><0.6\mu\text{m}</math>)
- Magnification 20x 40x
- Application Observation of biological sample, bright observation required fluorescence imaging, etc.

\*Custom design available  
\*Oil immersion type also available.



Product	40x water immersion objective lens	20x water immersion objective lens
Lens type	Plan Apochromat	
Wavelength	Visible (400 - 700nm)	
Magnification	40x (tube lens f=180mm)	20x (tube lens f=180mm)
NA	1	0.97
Working distance (W.D.)	0.3mm	2.0mm
Resolution	0.34 $\mu\text{m}$ ( $\lambda=0.55\mu\text{m}$ )	0.35 $\mu\text{m}$ ( $\lambda=0.55\mu\text{m}$ )
Focal length	$\pm 0.28\mu\text{m}$	$\pm 0.29\mu\text{m}$ ( $\lambda=0.55\mu\text{m}$ )
Transmittance	550nm $\geq$ 85% *365nm $\geq$ 45%	550nm $\geq$ 87% *365nm $\geq$ 25%
Parfocal length	75.0mm	75.0mm
Immersion	Water immersion	
Thread	M25 P=0.75	
Field curvature	<math><0.6\mu\text{m}</math> (at maximum image height)	
TWE	RMS : <math><70\text{m}\lambda</math>	
Weight	0.5kg	0.4kg
Others	Water proof and spring at tip end	

## High performance lens unit

High performance lens unit with water immersion objective lens. Ideal to observe the thick sample, sample is apart from the cover glass or observe inside the sample.

WD=2mm (MAX) for 20x

Lens

Water

Sample

Eyeball of rat.

Dermis of rat.

Cerebrum of rat.

- High NA (NA=1.0)
- Low aberration (field curvature image height: <math><0.6\mu\text{m}</math>)

# Custom-made

## X-ray Coaxial Zoom Observation System

When aligning microcrystals such as proteins in line analysis, a transmission hole is required at the center of the objective lens in order to irradiate X-rays simultaneously with observation.

We offer integrated manufacturing from lens polishing to coating and assembly, so custom-made products for various objective lenses are available according to customer requirements.

It can also be used as an application using neutron beams or vacuum ultraviolet beams.

● Application example : X-ray coaxial zoom observation system with standard zoom lens barrel.

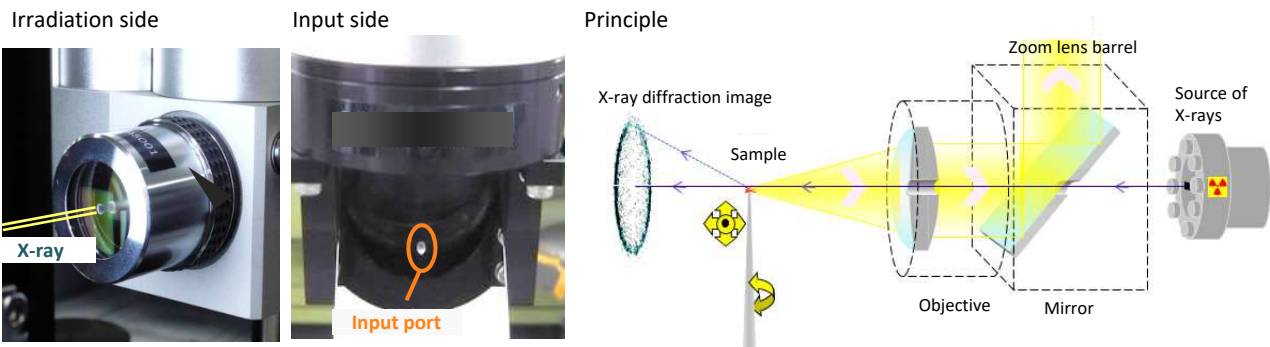

**System configuration example**

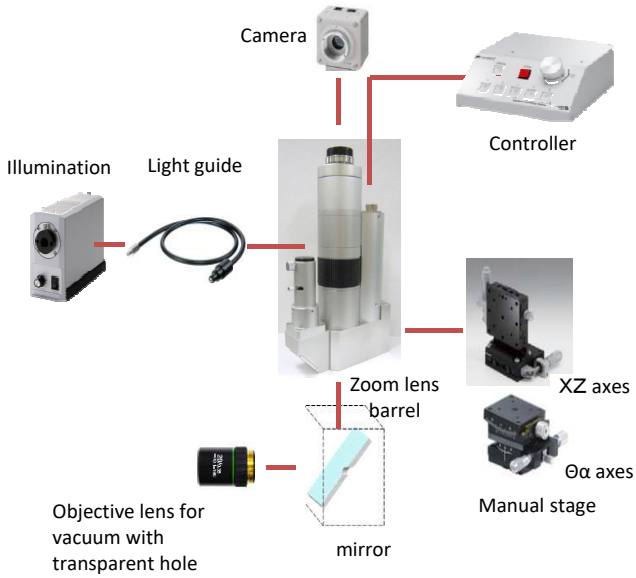

**Outline drawing (Reference: Zoom lens barrel)**

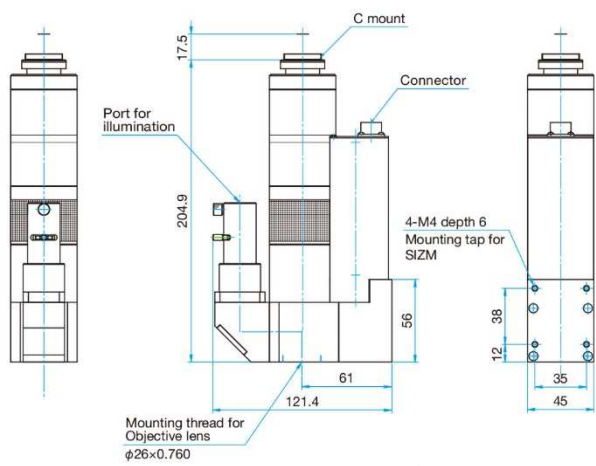

# Custom-made

## Objective Lens for Vacuum with Transparent Hole PLLW/PALLW



Objective lens for vacuum with transparent hole.  
 Stainless steel without surface treatment to prevent outgassing.  
 A through hole for degassing to discharge air between the lens at the side of the lens barrel.  
 A transparent hole to transmit X-ray at the center of the hole. Objective lens for vacuum without transparent hole also available.

### Outline Drawing

PLLW-5-HV

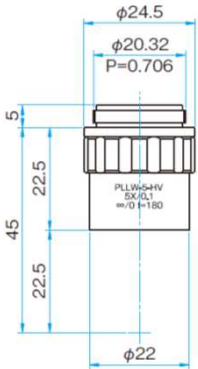

PLLW-10-HV

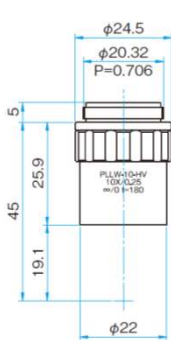

PLLW-20-HV

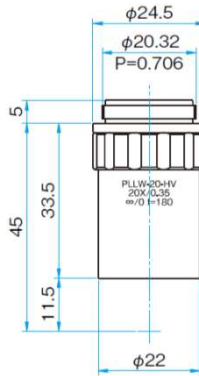

PALLW-10-HV

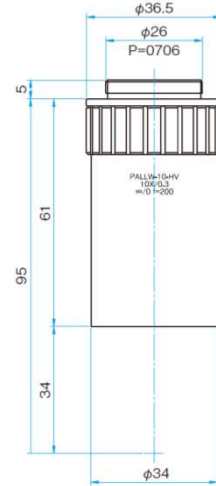

### Specs combined with Telecentric zoom microscope (SIZM)

Part Number	Optical Magnification *1	Hole dia. (cavity*2) [mm]	Focal length [mm]	Parfocal length [mm]	Working distance (W.D.) [mm]	NA	resolution [μm]	Image circle [mm]	FOV of camera (1/2 inch)*1 [mm]
PLLW-5-HV	1.4 - 19.4	φ1.5	36	45	22.5	0.1	3.4	φ5.2 - φ11	X 3.7 - 0.33 Y 3.4 - 0.25
PLLW-10-HV	2.8 - 38.8	φ1.5	18	45	19	0.25	1.4	φ5.2 - φ11	X 1.9 - 0.16 Y 1.7 - 0.12
PLLW-20-HV	5.6 - 77.6	φ1.5	9	45	11.5	0.35	1	φ5.2 - φ11	X 0.93 - 0.08 Y 0.86 - 0.06
PALLW-10-HV	2.5 - 35	φ1.5	20	95	34	0.3	1.2	φ5.2 - φ11	X 2.1 - 0.18 Y 1.9 - 0.14

\*1 Optical magnification is the magnification combined with zoom lens (SZL)  
 \*2 Field of view will be narrowed due to the performance for low magnification.

## Custom Lens Design

We support to design, manufacture and OEM supply of various kinds of custom lens based on our many years of experiences on optical design, polishing, coating and assembly technology.

### ■ Custom lens design example

- Large aperture fθ lens (scan area 180mm)
- Machine vision lens with mega-pixels
- Projection lens for exposure system
- objective lens for fs laser
- Variable spherical aberration correction objective lens
- Phase contrast microscope unit
- Differential interference microscope unit

# Telecentric Zoom Microscope

**SIZM**

**RoHS**

**Catalog Code**

**W2067**

Infinity corrected type lens tube with zoom.

- Compact light body
- Zoom ratio: 14x
- C mount designed
- Equipped with a port for coaxial epi-illumination
- Infinity corrected objective lens can be used
- Motorized zooming type
- Compatible from low to high magnification

## Outline Drawing

SIZM

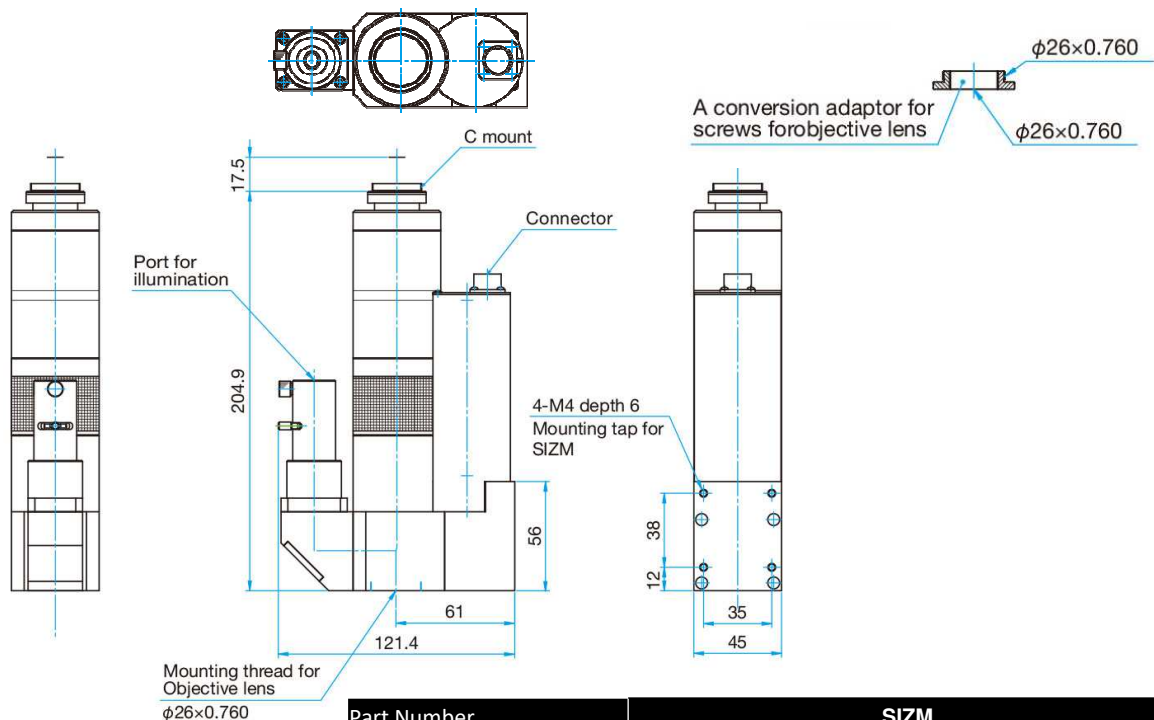

Part Number	SIZM
Manipulation for zoom	Motorized by controller
Zoom ratio	14
Focal length [mm]	50 - 700
Type	Infinity correction
Corrected Wavelength range [nm]	400 - 700
Image size [mm]	φ8 (for 1/2 inch sensor size)
Camera Mount	C mount
Illumination	Coaxial epi-illumination (standard)
Mounting screws for objective lens	φ26 x 0.760 φ20.32 x 0.760 Please use the attached conversion adaptor
Outline Drawing [mm]	204.9 x 121.4 x 45
Weight [kg]	1.5

\* Vignetting at four corners of the screen for the wide are zoom.

# Diagram

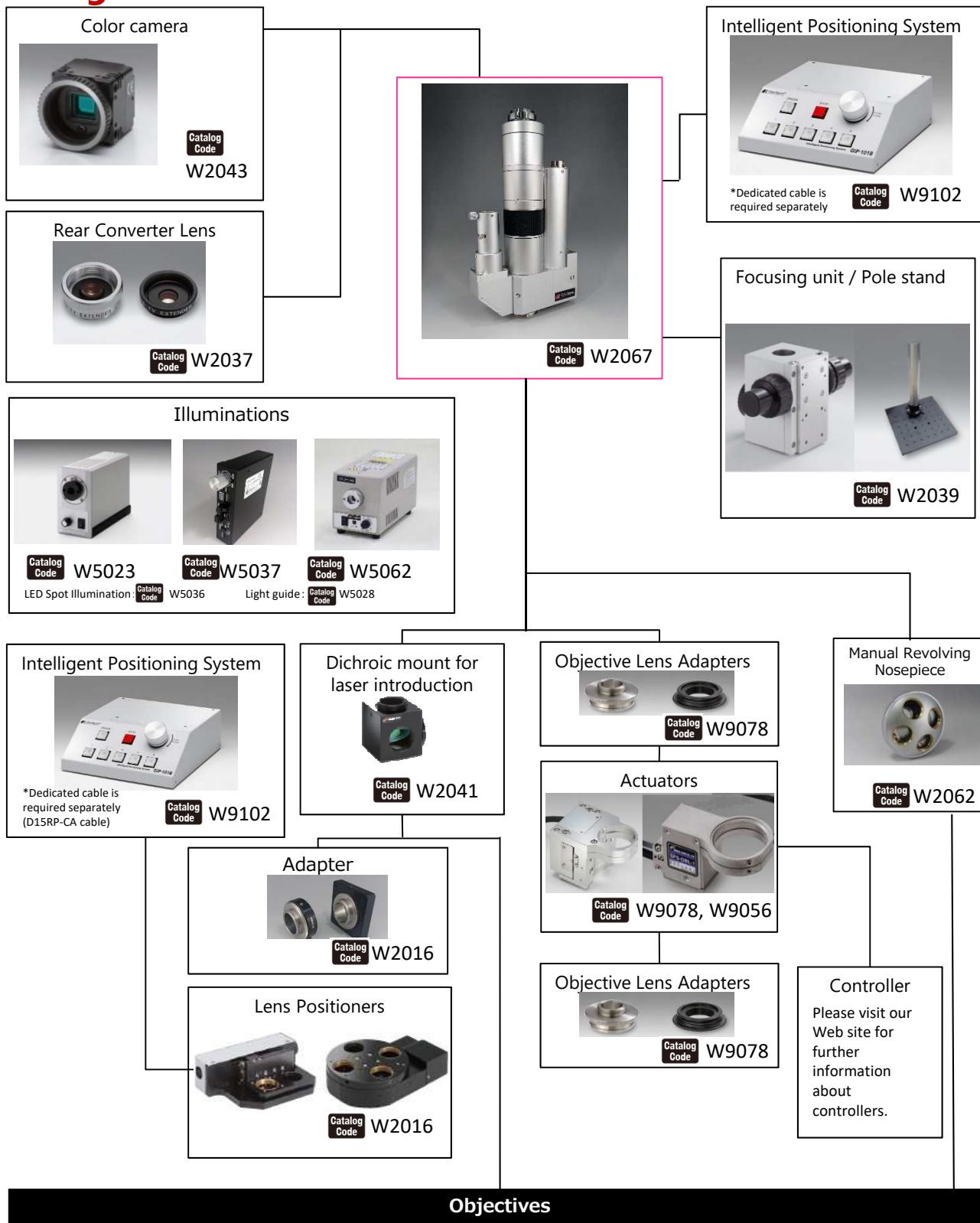

# Observation Unit with Coaxial Illumination **OUCI** RoHS Catalog Code W2012

This compact microscope is a customizable high performance imaging system for use in a wide range of applications from scientific research to industrial production equipment.

- A wide variety of options is available for Infinity corrected optical systems.
- Optional parts such as translation stages or illumination light-source could be found in our catalog.
- Optional parts such as translation stages or Illumination light-source could be found in our catalog.

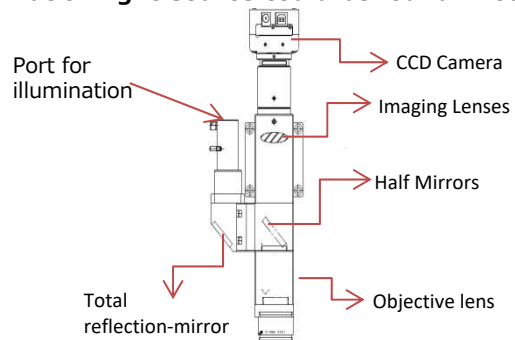

## Outline Drawing

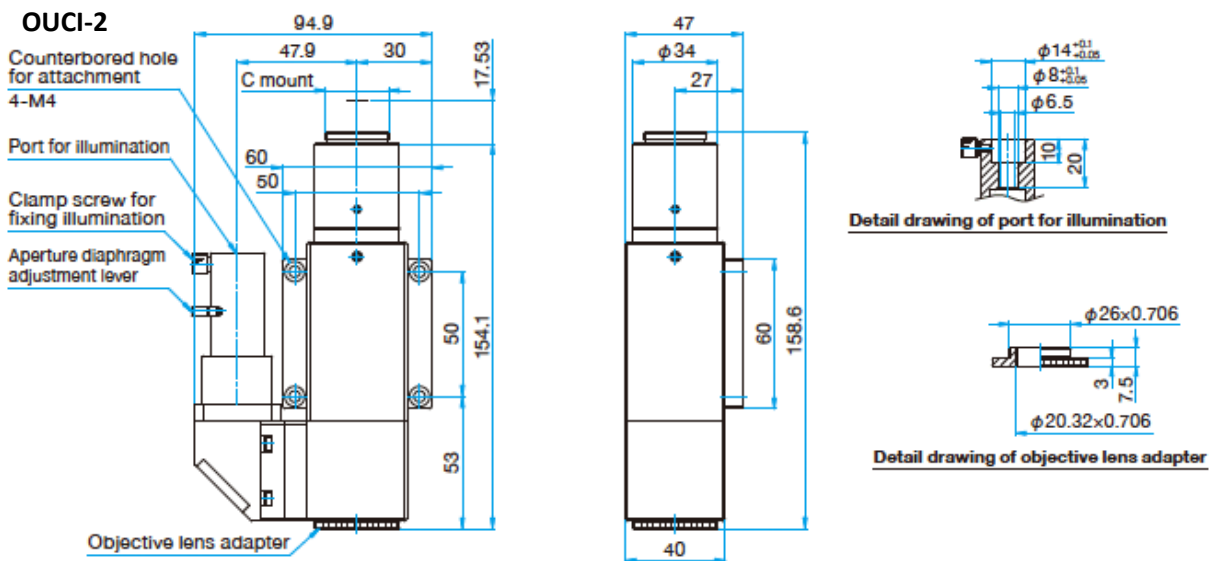

Part Number	OUCI-2
Imaging lens focal length	1x (200mm)
Observation image	Bright field
Camera mount	C mount (flange back 17.526mm)
Applicable camera	less than 2/3 inch
Illumination	Coaxial epi-illumination
Port for illumination	Refer the drawing above
Applicable objective lens	Infinity corrected objective lens
Thread for objective lens	φ26x0.706, φ20.32x0.706
Weight [kg]	0.65

# Observation Unit with Coaxial Illumination with 2 Camera Port

**OUCI-M1M1** RoHS Catalog Code W2012

- Observation with coaxial illumination by 2 cameras is possible
- Possible to be combined with a large range of optional parts in accordance with its application.
- Optional parts such as translation stages or Illumination light-source could be found in our catalog.



## Outline Drawing

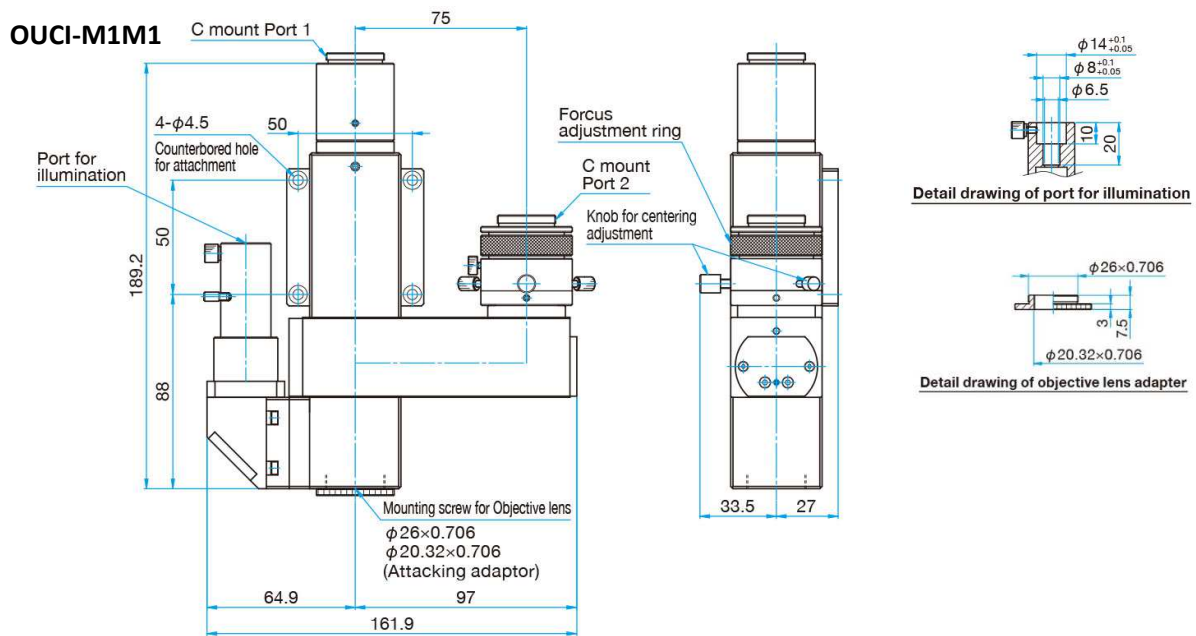

Part Number		OUCI-M1M1
Imaging lens focal length	Port 1	1x (200 mm)
	Port 2	1x (200 mm)
Observation image		Bright field
Camera mount		C mount (flange back 17.526mm)
Applicable camera size		Less than 2/3 inch
Illumination		Coaxial epi-illumination
Illumination port		Refer the drawing above
Applicable objective lens		Infinity corrected objective lens
Thread for objective lens		Φ26 x 0.706, φ20.32 x 0.706
Weight [kg]		1.25

# Diagram

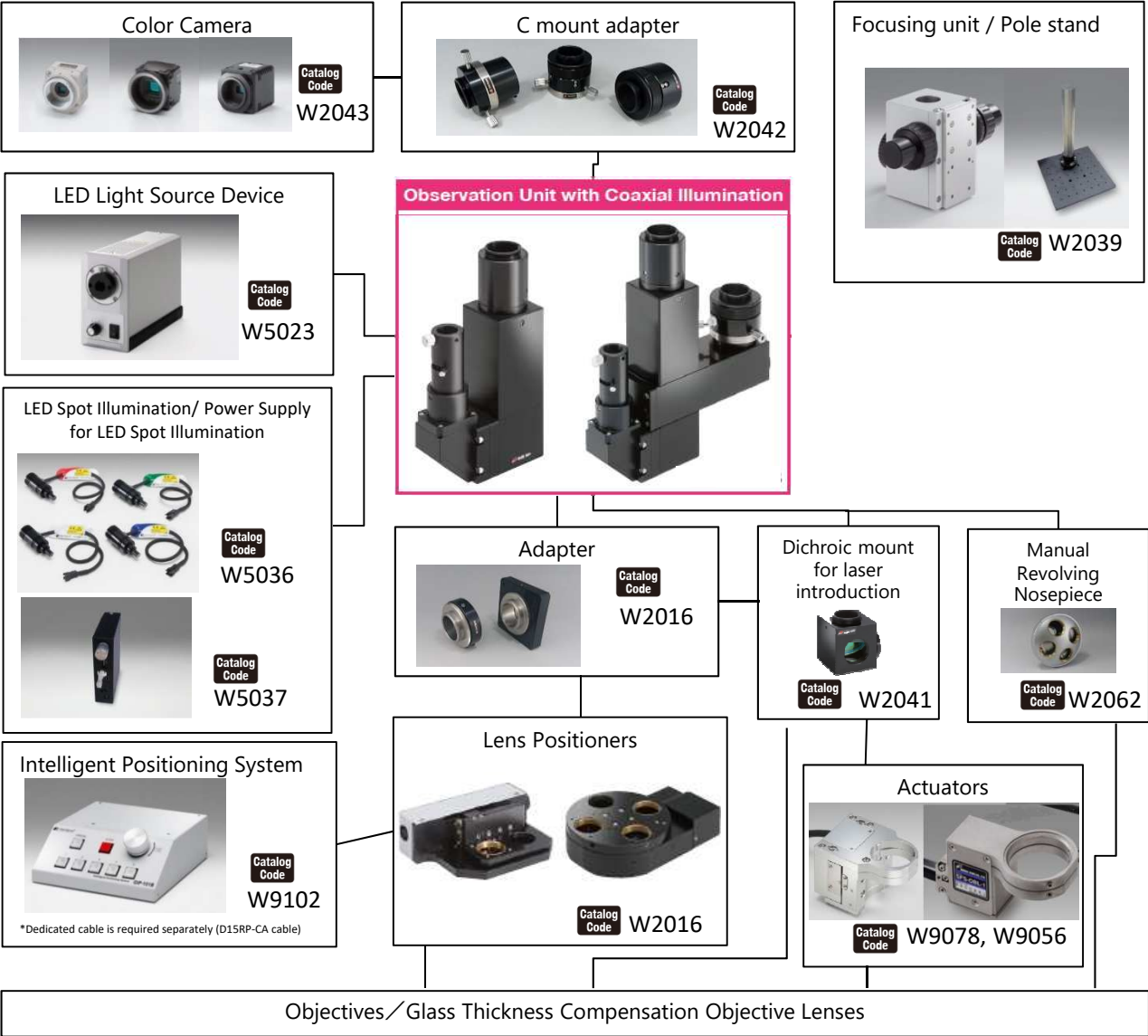

Visible

UV

NUV



Near-infrared

Custom-made

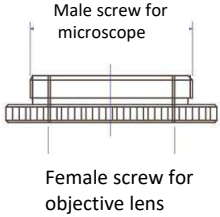



# Option

## Dichroic mount for laser introduction **DIMC**

**RoHS** Catalog Code **W2041**

Allows the introduction of a laser beam into the optical path of the OUCI micrometer body products.



### Outline Drawing

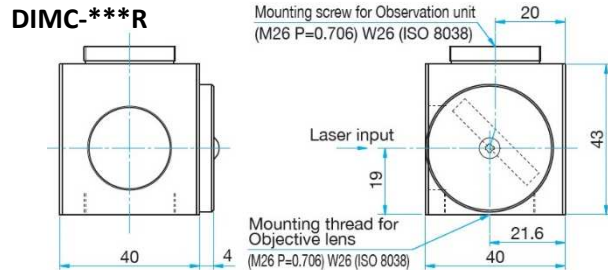

Part Number	Wavelength Range [nm]	Input aperture [mm]	Reflectance [%]	Laser Damage Threshold [J/cm <sup>2</sup> ]*
DIMC-355R	355	φ10	>99.5 (355nm)	5 (355nm)
DIMC-532R	532	φ10	>99.5 (532nm)	8 (532nm)
DIMC-1064R	1064	φ10	>99.5 (1064nm)	20 (1064nm)

\*Laser pulse width 10ns, repetition frequency 20Hz.

### Spectral Distribution

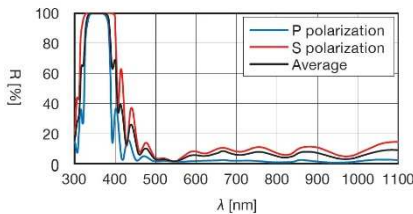

DIMC-355R

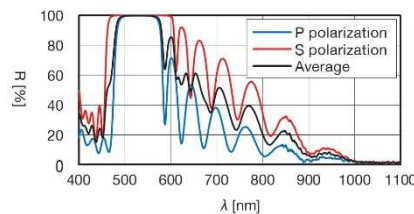

DIMC-532R

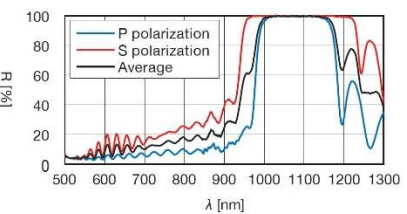

DIMC-1064R

## Actuator for Objective Lenses

**SGSP-OBL**

**RoHS** Catalog Code **W9078**

## Piezo Actuator for Objective Lens

**SFS-OBL**

**RoHS** Catalog Code **W9056**



### Outline Drawing

#### SGSP-OBL-3

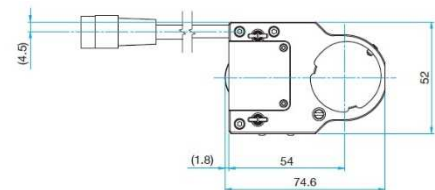

Part Number	SGSP-OBL-3
Actuator	Stepping Motor
Travel	3mm
Resolution [FULL/HALF]	1μm / 0.5μm
Positioning Accuracy / Positional Repeatability	5μm / 2μm
Load Capacity [N]	4.9 (0.5kgf)
Weight [kg]	0.4

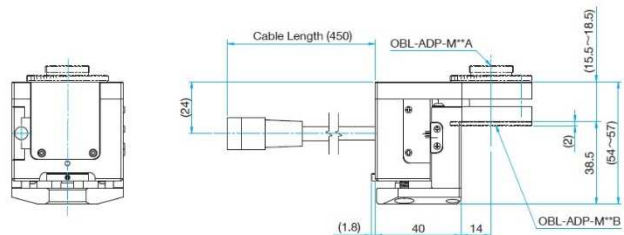

\*Optional adaptor should be needed when connect with a microscope or mount an objective lens. Please visit our Web site for further information.

### Outline Drawing

#### SFS-OBL-1

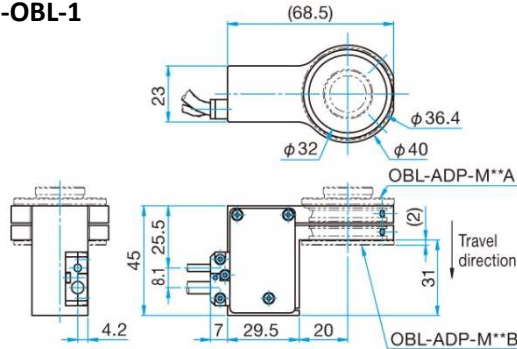

Part Number	SFS-OBL-1
Actuator	Piezo element
Travel	100μm ±15%
Theoretical Resolution (open-loop)	1nm [when using FINE-01]
Resolution (closed-loop)	10nm [when using FINE-01]
Positional Repeatability	<0.1μm
Weight [kg]	0.15

## Lens Positioners LACR/LACS

CE RoHS Catalog Code W2016

### Outline Drawing

#### LACR-4H

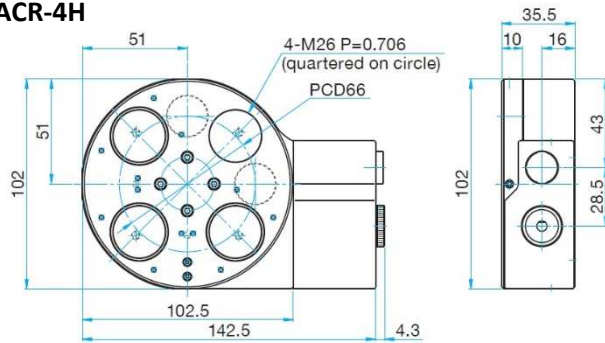

#### LACS-2H-A

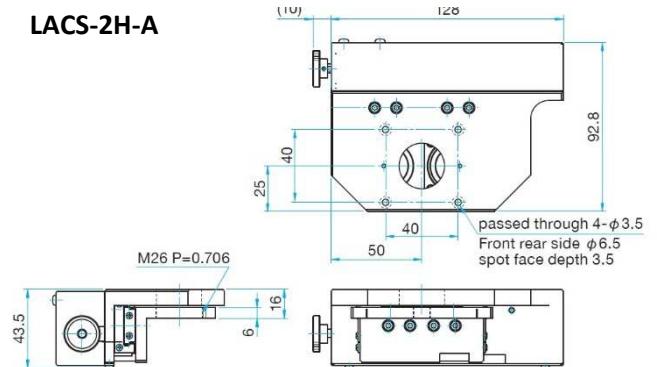

Part Number	LACR-4H	LACS-2H-A
Number of switched lens	4 holes (90° x4) (1hole: datum hole, 3holes: one-directional center core adjustment)	2 holes (1hole: datum hole, 1holes: one-directional center core adjustment)
Motor	5-phase stepping motor (0.75A/phase)	5-phase stepping motor (0.75A/phase)
Travel	∞ for both of clockwise and anticlockwise directions	35mm
Travel per 1 pulse	0.01° (FULL) / 0.0002° (1/50 DIV)	2μm(FULL) / 0.1μm (20 divided)
Positional repeatability	≤ 0.02deg.	—
Switching reproducibility	≤ +/-3μm (at the tip of objective lens)	≤ ±3μm (by the tip of objective lens)
Objective lens size	φ26x0.706 [Option: φ20.32 x 0.706]	φ26x0.706 [Option: φ20.32 x 0.706]
Weight [kg]	0.85	0.7

### To align electric revolver (LACR-4H)

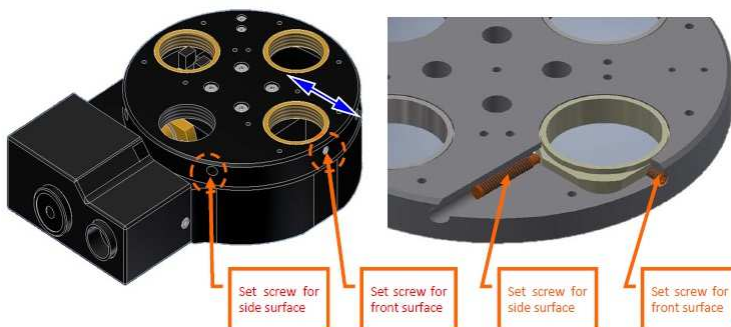

- 1) To adjust the angle in rotation the direction, adjust the number of pulses of the controller.
- 2) One-way center adjustment (blue arrow direction) can be performed as electric revolver.
- 3) By adjusting the M4 set screw on front/side, can adjust front/rear of about ± 0.3 mm.
- 4) Centering can be adjusted at three points with the same adjustment.

# Manual Revolving Nosepiece

## MLT-4H

Catalog Code **W2062**

### Outline Drawing

#### MLT-4H

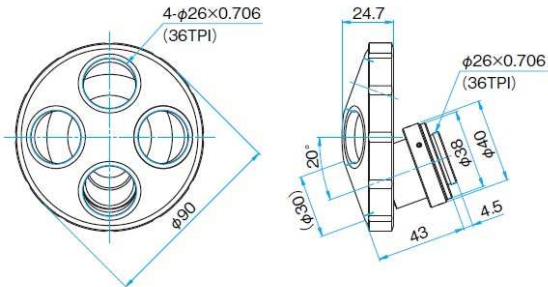

It is compatible with our observation unit with coaxial illumination (OUCI-2) and can be fixed in place.

Part Number	<b>MLT-4H</b>
Number of switched lens	4 Holes (spaced at 90 degree intervals)
Observation Method	Bright field Observation
Compatible Objective Thread	φ26 x 0.706 (36 threads per inch)
Compatible Barrel Thread	φ26 x 0.706 (36 threads per inch)
Weight [kg]	0.57

# C mount adapter

## CACM

**RoHS** Catalog Code **W2042**



It is used for centering with C mount camera , or for focus adjustment. (Can be attached to OUCI-2 or two port type observation unit with coaxial illumination.)

Part Number	<b>CACM-1</b>	<b>CACM-2</b>	<b>CACM-3</b>
Centering adjustment range [mm]	φ0.2	φ0.2	—
Focusing Adjustment range [mm]	—	3	3
Weight [kg]	0.1	0.11	0.08

### Outline Drawing

#### CACM-1

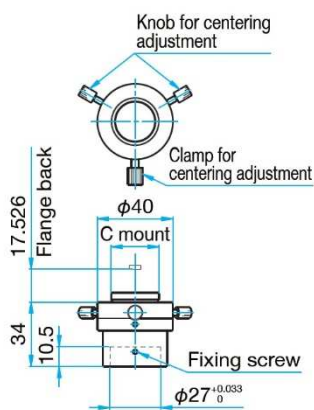

#### CACM-2

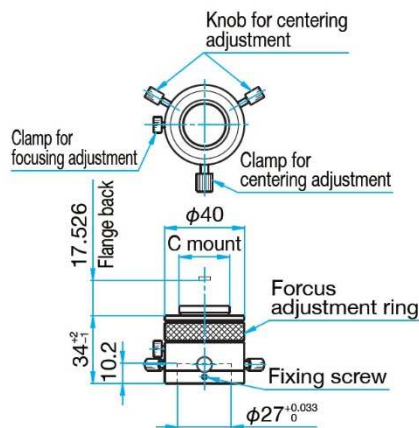

#### CACM-3

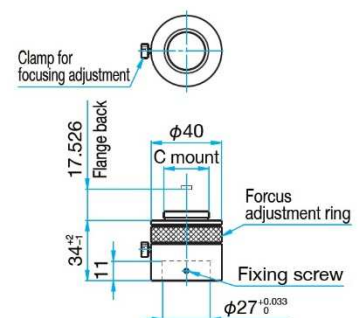

## LED Light Source Device

## SLA-100B

Catalog Code W5023

### Outline Drawing

SLA-100B

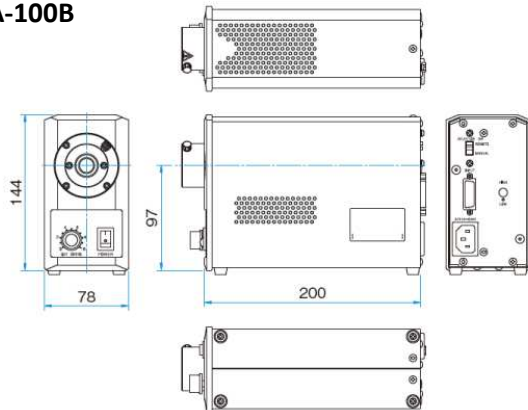

Part Number	SLA-100A
Luminescence color	White light
Power Consumption	20W [AC100-240V±10%]
Weight [kg]	2.0

## Halogen Light Source Illuminating Systems SHLA-150

Catalog Code W5062

### Outline Drawing

SHLA-150

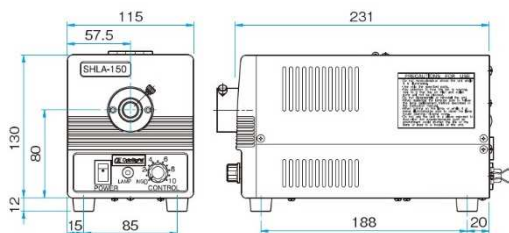

Part Number	SHLA-150
Color Temperature	3,100K - 3,200K
Power Consumption	180W [AC100 - 120V±10%]
Weight [kg]	2.6

## Light Guides

MSL Catalog Code W5028

RoHS



Part Number	MSL-1000F	MSL-1500F
Type	Straight flexible	
Coating	Tube	
Length [mm]	1,000	1,500

## Others

Catalog Code W2039



Focusing unit

Pole stand

Various types are available.  
Please visit our Web site for further information.

## LED Spot Illumination **SLSI**

Catalog Code **W5036**

It is suit for being used with an observation unit or microscope which has coaxial illumination. There are four types of variation : White, Red, Green and Blue.



- Useful for coaxial epi-illumination for our zoom microscope, ultra long working distance zoom microscope, observation unit with coaxial illumination, and various telecentric lenses.
- Useful for spot illumination.
- Extension cable (Option : FCB/FRCB series) are available. Catalog Code W5047
- Light guide for LED spot illumination (Option : S1/S2 series)
- An adopter for Light guide is available (Option : AD-0808). After connect with LED spot illumination, it can realize Ring illumination or Line illumination

### Outline Drawing

SLSI-22\*

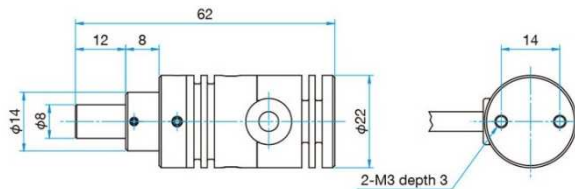

Part Number	Luminescence Color	Maximum Rated Current [A]	Weight [kg]
SLSI-22W	White ○	0.7	0.04
SLSI-22R	Red ●	0.7	0.04
SLSI-22G	Green ●	0.7	0.04
SLSI-22B	Blue ●	0.7	0.04

## Power Supply for LED Spot Illumination **SPS-SLSI**

Catalog Code **W5037**

SPS-SLSI is a power supply for LED Illuminations. It features a palm-size slim body capable of being mounted on a DIN rail.

In addition, it allows dimming by volume or USB control.



- Easy connection to the spot light and brightness control. Adapter available for connection to DIN rail.
- LED ON/OFF and brightness control are possible by PC with USB interface.
- Flash function is available with external trigger input.

### Outline Drawing

SPS-SLSI

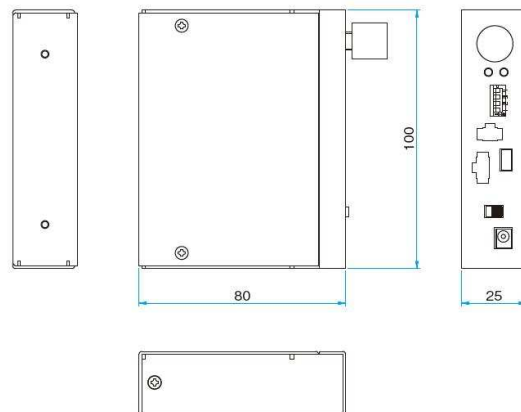

Part Number	<b>SPS-SLSI</b>
Controllable Number of LED	1ch
Power Voltage	AC100 - 240V ± 10%
Apparent Power	30VA
Operating Temperature/Storage Temperature	5 - 40°C / -20 - 60°C
Functions	Dimming by volume control, USB control, flash operation, external gate operation
External Output	Output for LED
Interface	USB (Mini-B type) USB1.1 compliant Trigger (Gate) Input Connector

## Technical Data

### 1. Parfocal Distance

The parfocal distance is the distance from the mounting shoulder of the objective to the focal plane where the specimen or cover glass is placed at. The parfocal distance of EPL/EPL series objectives is 45mm and it is 95mm for other objectives.

### 2. W.D. (Working Distance)

The working distance is the distance from the vertex of the objective lens to the focal plane where the specimen or cover glass is placed.

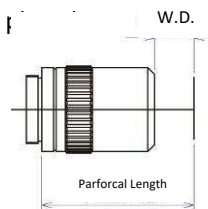

### 3. Infinity-Corrected Optical System

In the infinity-corrected optical system, the object is imaged by objective and the imaging lens. The collimated beam between the objective and the imaging lens allows the beam splitters or filters to be introduced into the optical path.

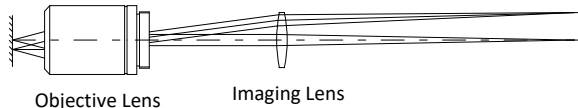

### 4. Finite Optical System

In the finite optical system, the object is imaged by objective only.

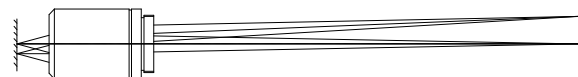

### 5. Focal Length and Magnification of Objective

The optical magnification of infinity-corrected optical system is given by the ratio of focal length of imaging lens to that of the objective.

$$\text{Objective Magnification} = \frac{\text{Focal Length of Imaging Lens}}{\text{Focal Length of Objective}}$$

### 6. Field Number and Field of View

The field size in the specimen plane of the microscope is controlled by the size of the field stop inside the eyepiece. The diameter of the field stop measured in millimeters is called field number of eyepiece.

The field size which can be viewed through eyepiece is expressed as

$$\text{Field of View (Diameter)} = \frac{\text{Field Number of Eyepiece}}{\text{Objective Magnification}} \text{ (mm)}$$

The field size displayed on the TV monitor is expressed as

$$\text{Field of View (W} \times \text{H)} = \frac{\text{Size of Image Sensor (W} \times \text{H)}}{\text{Objective Magnification}}$$

• Common image sensor sizes

Format	Diagonal	Width	Height
1/3"	6.0mm	4.8mm	3.6mm
1/2"	8.0mm	6.4mm	4.8mm
2/3"	11.0mm	8.8mm	6.6mm

### 7. Monitor Magnification and Magnification on Monitor

Monitor magnification and magnification on the TV monitor are expressed as

$$\text{Monitor Magnification} = \frac{\text{Monitor Size (Diagonal)}}{\text{Image Sensor Size (Diagonal)}}$$

Magnification on Monitor = Objective Magnification

\*Monitor Magnification

### 8. N.A. (Numerical Aperture)

Numerical aperture is expressed as

$$\text{N.A.} = n \times \sin \theta$$

where n is the refractive index of the medium between the specimen and objective (n = 1.0 in air),  $\theta$  is the angle between a marginal ray and the axis. The resolving power, the depth of focus, and the brightness of the microscope are determined by the NA of the objective.

### 9. Resolving Power

Resolving power is the ability to resolve two points which are close together at object surface. It is determined by the objective N.A. and the operating wavelength (generally 0.55 $\mu$ m for visible light) and can be given by the Rayleigh criterion:

$$\text{Resolving Power (r)} = 0.61 \times \frac{\text{Lambda}}{\text{N.A.}}$$

However, two points separated by

$$0.5 \times \frac{\lambda}{\text{N.A.}}$$

can be barely resolved by Sparrow criterion.

The larger the N.A., the higher the resolving power.

## 10. D.F. (Depth of Focus)

When the specimen is being focused, the image may be shifted longitudinally somewhat and this will not introduce unacceptable blur. The amount of such shift is called depth of the focus.

The abilities of the human eye's focus adjustment vary widely from individual to individual. This results in the variation of the depth of focus when an eyepiece is used for observation. Berek's formula which gave good agreement with the experiments is presently used to express the depth of focus

$$\text{Depth of Focus } \pm D = \frac{w \times 250000}{\text{N.A.} \times M} + \frac{\text{Lambda}}{2 \times \text{N.A.}}$$

(Berek's formula)

Where  $w$  is resolving power of eye (0.0014 when the visual angle of the eye is 5 arcmins), N.A. is numerical aperture of objective,  $M$  is total magnification (=Objective Magnification \* Eyepiece Magnification),  $\text{Lambda}$  is operating wavelength (0.55 $\mu\text{m}$  for visible light), and 250000 is distance of distinct vision.

## 11. Kohler Illumination

Kohler illumination is an optical system that provides uniform illumination over the specimen plane. The light source is imaged at aperture stop of the condenser lens and then relayed to the exit pupil of the objective. Therefore the specimen plane is uniformly illuminated with the light source at infinity.

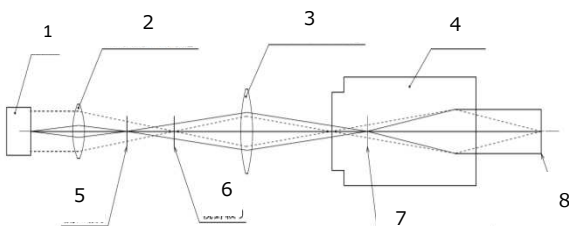

- |                   |                                       |
|-------------------|---------------------------------------|
| 1: Light Source   | 6: Field Stop                         |
| 2: Condenser Lens | 7: Objective Lens exit pupil position |
| 3: Condenser Lens | 8: Plane of a Specimen                |
| 4: Objective lens |                                       |
| 5: Aperture Stop  |                                       |

## - Field Diaphragm

The field diaphragm is used to block the illumination outside the field of view. This serves to eliminate excess incident light and prevent glare.

## - Aperture Stop

Aperture stop is used to adjust the N.A. of the light for the illuminating. Usually, a good balance between the resolving power and contrast can be achieved by adjusting the diameter of the aperture stop to 80% of the pupil diameter.

## 12. Pupil Diameter of the Objective

The maximum diameter of a collimated light beam that can enter from the rear side of the objective along optical axis is called pupil diameter of an objective. It is given by

$$\text{Pupil Diameter} = 2 \times f \times \text{N.A.}$$

Where  $f$  is the focal length of objective and N.A. is the numerical aperture respectively.

## 13. Spot Diameter Focused by the Objective

When a collimated laser beam with flat intensity across the field enters the objective from the rear side, the focused spot size can be roughly given as

$$\text{Spot Diameter} = 1.22 \times \frac{\text{Lambda}}{\text{N.A.}}$$

Where  $\text{Lambda}$  is wavelength and N.A. is the numerical aperture of objective.

The intensity distribution of the focused spot is given by besell function and the spot diameter is equal to the diameter of the first dark ring (Airy disk).

### 14. Gaussian Beams

The laser beam intensity has Gaussian distribution that is rotationally symmetric about the central axis (optical axis). The radius at where the beam intensity decreases by the factor  $1/e^2$  (13.5%) with respect to the peak value on the beam axis is called beam radius.

$$I(r) = I_0 e^{-2r^2/w^2}$$

where  $I_0$  is the peak intensity,  $w$  is beam radius, and  $r$  is the radial distance

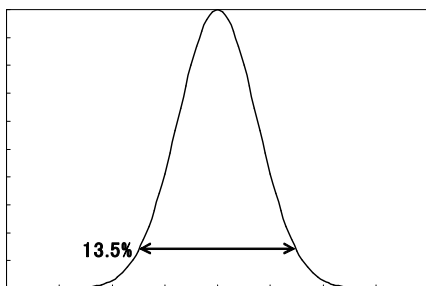

### 15. Beam Waist and Divergence Angle

There is a minimum beam diameter also called the beam waist somewhere between the two mirrors of a laser resonator. The wavefront is planar at beam waist and curved away from the beam waist due to effects of diffraction. The beam width increases monotonically with distance  $z$  from the beam waist and can be expressed as

$$w(z) = w_0 \left[ 1 + \left( \frac{\lambda z}{\pi w_0^2} \right)^2 \right]^{1/2}$$

where  $w_0$  is the radius of beam waist and  $\lambda$  is the wavelength.

when  $z$  is large and  $w_0$  is small

$$w(z) \approx \frac{\lambda}{\pi w_0} \times z$$

The divergence angle is inversely proportional to the waist diameter.



### 16. Focusing of Gaussian Beam

When a Gaussian beam is focused by a lens placed sufficiently far away from the beam waist, the focusing spot diameter can be expressed as the equation below. The lens must have an aperture diameter larger than twice the beam diameter to keep Gaussian intensity distribution over focusing spot.

$$\text{Spot Diameter } \varphi = 2 \times \frac{\lambda \times f}{\pi w(s)}$$

where  $\lambda$  is the wavelength of the laser,  $f$  is the focal length of the lens,  $s$  is the distance from the beam waist, and  $w(s)$  is the incident beam radius on the lens.

### 17. The Lens Aberrations

Aberrations that affect imaging performance can be classified as following.

Five Primary or Seidel aberrations

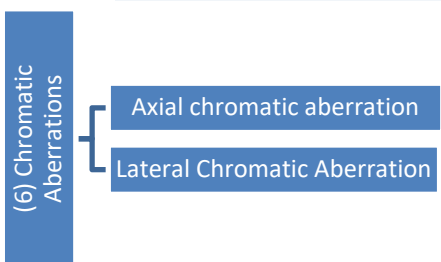
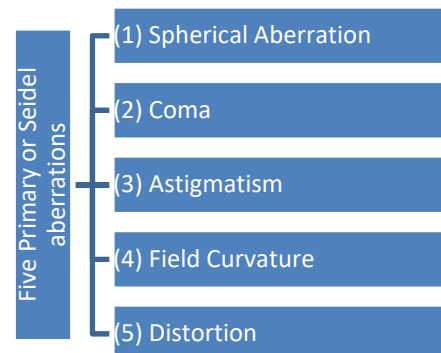

Aberrations (1)-(3) affect the size and shape of the point spread function. Aberrations (4)-(5) deform the image. Aberration (6) is wavelength dependent aberration.

### (1) Spherical Aberration

Rays issued from an on-axis source at infinity do not all converge at the same point and the focus of the marginal rays is different from the focus of the paraxial rays. The larger the incident beam diameter, the larger the effect of spherical aberration.

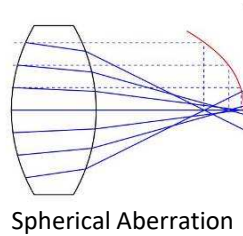

Spherical Aberration

### (2) Coma

Aberration which causes the image of an off axis point object to be deformed like a comet tail is called coma. Aplanat is the lens corrected for spherical aberration and coma.

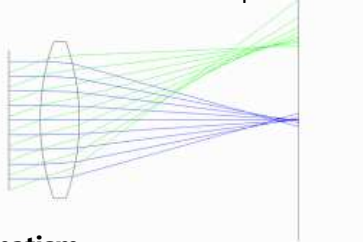

### (3) Astigmatism

The focus of rays in the plane containing the system axis and an off-axis object point is different from the focus of rays in the perpendicular plane.

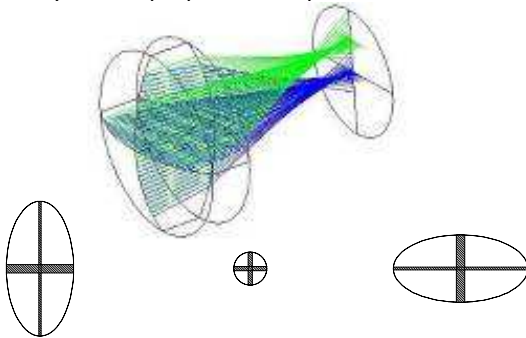

### (4) Field Curvature

Field curvature causes a planar object perpendicular to the system axis to have curved image plane. Usually, both the object and the image sensor are plane and field curvature must be corrected to obtain focused image from the center to the edges.

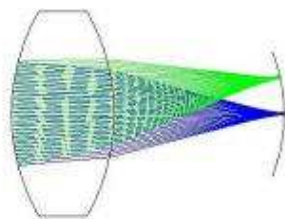

### (5) Distortion

The shape of the image does not match with that of the object and shows difference depending upon the position in the field. Such monochromatic aberration is called distortion. In a lens without distortion, the image height is given by  $f \times \tan \theta$ , where  $f$  is the focal length of the lens and  $\theta$  is the angle of incidence. In a lens with distortion, the image points shift from their ideal height. F-theta lenses are designed to have deliberate distortion so that the image height is proportional to the scanning angle  $\theta$  rather than  $\tan \theta$ .

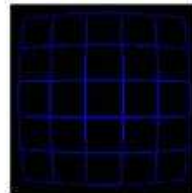

Barrel Distortion

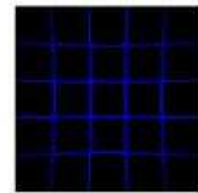

Pincushion Distortion

### (6) Chromatic Aberrations

Light of different wavelengths is focused at different points along the optical axis is called axial chromatic aberration, and the image size varies with the wavelength is called lateral chromatic aberration.

achromat and apochromat are objectives in which chromatic aberration is corrected for two wavelengths and three wavelengths respectively.

### 18. Cover Glass Thickness Compensation

The cover glass between the objective and the object can introduce spherical aberration and reduce imaging performance. By use of an objective which is designed to be corrected for spherical aberration for a specific cover glass thickness, microscope observation or laser processing through the cover glass can be achieved.

## 19. F-theta Lens

An f-theta lens is designed to produce constant linear scan velocity over its focal plane when the incident laser beam is turned under constant angular velocity by use of the polygon-mirror or the galvano-mirror. The angle of the incident chief ray upon the focal plane increases with that of the incident scan beam upon the lens. F-theta lenses are commonly used in the applications such as laser printer and laser marker.

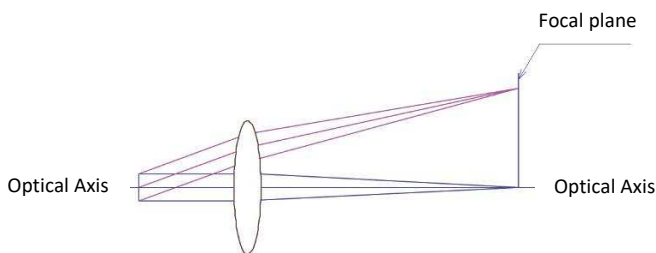

## 20. Telecentric F-theta Lens

Such f-theta lens is designed to let the chief ray of the scanning laser beam output from the lens be parallel with the axis. The chief ray of the laser beam with any incident angle upon the lens always strikes the focal plane normally.

The using of a non-telecentric f-theta lens for laser drilling may result in the tilted axis of the hole at the position away from the axis of the lens. The axis of the hole is still normal to the focal plane when a telecentric f-theta is used.

Telecentric f-theta lens provides a perpendicular angle of the laser beam onto the focal plane. This means that the size of the lens at the output side must be larger than the scan area so that a telecentric f-theta lens is usually larger and heavier than a non-telecentric f-theta lens.

Telecentric f-theta lenses are commonly used in the applications such as via hole drilling and cutting.

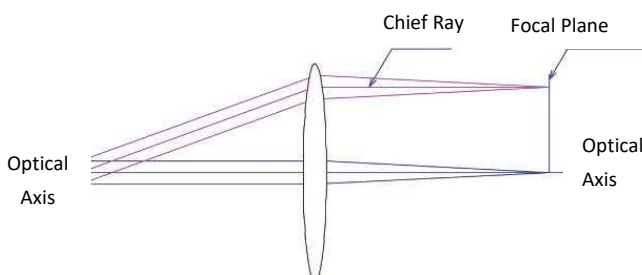

## 21. Maximum Input Beam Diameter

This spec gives the maximum beam diameter incident to the f-theta lens. To achieve designed performance at the focal plane, the input beam diameter must be smaller than this value. The maximum input beam diameter of our f-theta lenses is defined as the beam diameter measured at  $1/e^2$  of the peak intensity.

## 22. Entrance Pupil

The scanning element such as galvano-mirror and polygon-mirror is positioned at the entrance pupil of the scan lens.

## 23. Maximum Scan Angle

This spec gives the maximum angle (optical angle) of the incident laser beam upon the f-theta lens.

## 24. Telecentricity Error

The chief ray emerges from a telecentric lens is ideally normal to the focal plane. Actually, it often deviates from the focal plane normal depending on the lens performance or the scanner position. The deviation (calculated value) is expressed as telecentricity error. For our f-theta lenses, it is defined assuming that the galvano scanner is placed at the given mirror distance.

## 25. Scan angle and Scanning Range

Scanning range of an f-theta lens is mathematically expressed as

$$y = f \times 2\theta$$

where  $y$  is ideal image height (mm),  $f$  is the focal length (mm), and  $\theta$  is the angle of scanned (rad)

## 26. Laser Damage Threshold

The laser damage threshold is defined as the highest fluence at which the extrapolated probability of damage caused by the laser irradiation is zero.

The laser damage threshold of our products was tested based on 200-on-1 testing procedure according to the international ISO 21254 standard. 200-on-1 test is a testing procedure that uses 200 shots of laser radiation on each unexposed site on the target optical component to confirm whether this causes damage or not. Another test procedure, called 1-to-1 test (one shot of laser radiation on each unexposed site), is adopted by some manufacturers. However, in most cases, continued laser irradiation is required and 1-to-1 test finishes before the occurrence of damage. Therefore, we adopt 200-on-1 test which is more practical.

The laser damage threshold tests of the antireflection (AR) coating on our f-theta lenses were done under the following laser condition: TEM<sub>00</sub> Mode, 10ns, 20Hz, AOI=0 Deg., Linear Polarization. Please note that the laser damage threshold is a tested value but not a guaranteed value.

For a proper evaluation of the laser damage threshold, the laser operating environment and the laser characteristics such as the pulse width, the repetition rate, and the state of polarization should be considered.

## 27. Position Polygon Mirror

In the case of one-dimensional scanning, the polygon mirror or one-axis galvano mirror is placed at the entrance pupil of the scanning lens.

(Figure: Polygon Mirror, Entrance Pupil, Focal Plane, Optical Axis, Position polygon mirror)

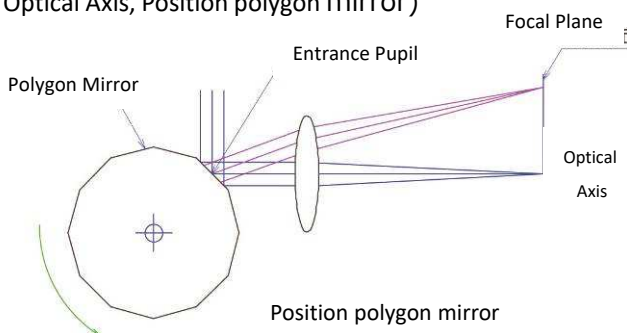

## 28. Galvano Scanner and Displacement between the Galvano Mirrors

A two dimensional laser scan at the focal plane of a scanning lens is commonly achieved by use of galvano scanner.

In order to get the full design performance, the mirror should be positioned at the entrance pupil of the f-theta lens. However, this is physically impossible because there are two mirrors. While the small changes in f-theta characteristics, field curvature, and telecentricity might be introduced, placing the two mirrors symmetrically with respect to the entrance pupil, and keeping them as close as possible may help to get best performance.

Using the f-theta lenses outside the given maximum input beam diameter and mirror displacement specifications may result in undesired effect.

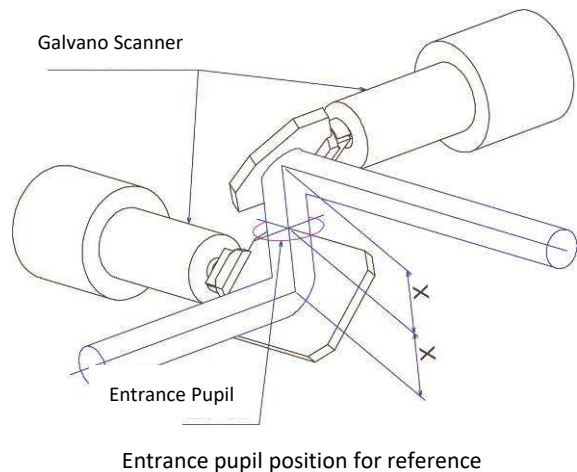

## F-theta Lens

Most lenses follow the relationship that the image height  $y$  at the focal plane is equal to  $f \times \tan\theta$ , where  $f$  is the focal length of the lens and  $\theta$  is the angle of laser beam upon to the lens. On the other hand, the f-theta lenses follow the relationship of  $y=f \times \theta$ .

In the former case,  $y$  is approximately proportional to  $\theta$  at small incident angle only.

By intentionally introducing a negative or barrel distortion, in the latter case,  $y$  is still proportional to  $\theta$ . Therefore, without applying the electronic compensation, the scanning system produce constant linear scan velocity over full focal plane of f-theta lens when the incident laser beam is turned under constant angular velocity by use of the polygon-mirror or the Galvano-mirror.

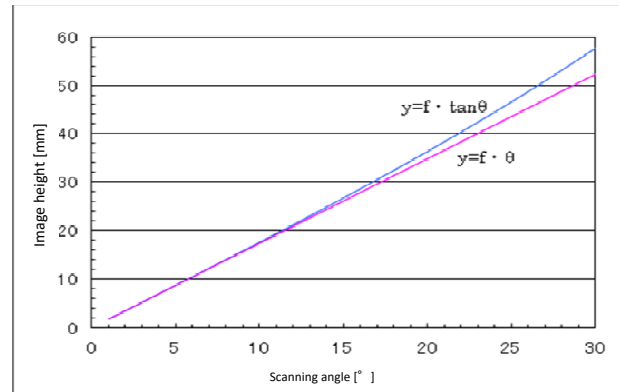

Image height vs. Scan angle (f=100)

## RoHS

### About our RoHS notation along with the revised "RoHS 2.0 Directive"

The substances prohibited by RoHS 2.0 will be changed to 10 substances from 6 substances with the revised RoHS Directive (RoHS 2.0) from July 22nd, 2019.

Four kinds of phthalate substances will be additionally prohibited as below.

Prohibited substances	Regulatory threshold	Note
Lead	Less than 1,000ppm	
Mercury	Less than 1,000ppm	
Hexavalent chromium	Less than 1,000ppm	
Polybrominated biphenyls (PBB)	Less than 1,000ppm	
Polybrominated diphenyl ethers (PBDE)	Less than 1,000ppm	
Cadmium	Less than 100ppm	
Bis(2-ethylhexyl)phthalate (DEHP)	Less than 1,000ppm	Additional substance
Butyl benzyl phthalate (BBP)	Less than 1,000ppm	Additional substance
Dibutyl phthalate (DBP)	Less than 1,000ppm	Additional substance
Diisobutyl Phthalate (DIBP)	Less than 1,000ppm	Additional substance

※The RoHS mark on our Website defines the ten(10) prohibited substances of the RoHS2.0 directive.

※The RoHS mark on our Catalog 02 and PDF catalog which can be downloaded from our website defines the six(6) prohibited substances of the RoHS directive.

#### Contact

Tokyo Head office TEL: +81-3-5638-8228 E-Mail: [international@sigma-koki.com](mailto:international@sigma-koki.com)

## Very popular with customers. Information on 「smart SIGMAKOKI」 series.

There are some tens of thousands products are printed in our general catalog O2 or web catalog. A huge amount of part numbers are printed in our web catalog including the web catalog limited products and more than ten thousands of part numbers are printed even only in general catalog O2 to cover various kinds of products. This time, we published 「*smart SIGMAKOKI*」 as an introductory of Sigma Koki's products. Using 「*smart SIGMAKOKI*」 will let you understand and link the part numbers and products. It might be difficult to image the products only from the part numbers before using 「*smart SIGMAKOKI*」 because of the huge amount of products. But after understanding the rules of part numbers, you might be able to image the products from the part numbers. By understanding the rules of part numbers and becoming be able to imagine the products from the part numbers, you can now make full use of general catalog O2 or web catalog to find the products you need.



Microscope  
Total 16page

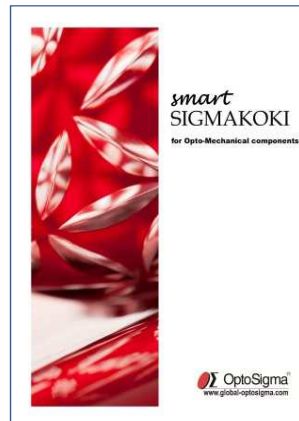

Opto-Mechanical components  
Total 24page



Optics version  
Total 36page



### “OptoSigma Mascot characters”



KOPMA

OPMA

All data on the catalog is copyrighted by the Company.  
We do not permit any unauthorized duplication, unauthorized reproduction or unauthorized copying.  
The names of the products and the specifications in this catalog are subject to change without notice for the sake of improvement.  
The information contained in this publication is based on the latest information available at the time of printing.  
©2019 SIGMAKOKI CO.,LTD. All right reserved.



## SIGMAKOKI CO.,LTD.

### Tokyo Head Office

5F, SIGMA KOKI Tokyo Head office 1-19-9,  
Midori, Sumida-ku, Tokyo, 130-0021, JAPAN  
TEL: +81-3-5638-8228 / FAX: +81-3-5638-6550  
E-mail international@sigma-koki.com